

RE

RE

RC2

5%~8%

GB19577-2015

1

COP

RE



XXX



X



m³/h

50HZ

A

B

RE

,

RE

,

RE

RE

RE

PTC PT100

			RE-230	RE-260	RE-300	RE-420	RE-480	RE-550	RE-620	RE-710	RE-820	RE-920	
压缩机	(50Hz)	Rpm	2950										
	(50Hz)	m ³ /h	232	266	307	417	481	554	625	712	820	924	
	VI		2.2 2.6 3.0 3.5 4.4										
		%	25, 50, 75, 100										
		%	25~100										
电机规格			3 2										
			550	Y- ,PWS, DOL					Y- ,DOL				
	(50Hz)	V	380										
			F										
			PTC										
		L	14	16	16	16	17	19	23	26	28	28	
		W	300										
		Bar	32										

(50Hz R134a ECO

RE-420B

		-5	0	5	10
25	(kW)	224.0	274.6	334.0	402.9
	(kW)	38.4	38.7	38.9	38.7
	(A)	67.1	67.7	67.9	67.7
30	(kW)	212.7	261.4	318.4	384.8
	(kW)	42.9	43.5	43.9	44.0
	(A)	74.2	75.1	75.7	75.9
35	(kW)	201.3	247.9	302.6	366.4
	(kW)	48.0	48.8	49.5	49.8



RE-550B

		-5	0	5	10
25	(kW)	286.0	350.7	426.5	514.7
	(kW)	48.2	48.6	48.8	48.6
	(A)	88.8	89.4	89.6	89.4
30	(kW)	271.6	333.7	406.6	491.4
	(kW)	53.9	54.7	55.2	55.2
	(A)	96.4	97.4	98.1	98.2
35	(kW)	256.9	316.5	386.4	467.8
	(kW)	60.3	61.3	62.1	62.5
	(A)	105.3	106.9	108.0	108.6
40	(kW)	241.8	298.8	365.8	443.9
	(kW)	67.2	68.6	69.7	70.4
	(A)	115.6	117.8	119.5	120.6
45	(kW)	226.2	280.6	344.7	419.5
	(kW)	74.7	76.5	77.9	79.0
	(A)	127.4	130.2	132.5	134.3
50	(kW)	209.9	261.8	323.0	394.6
	(kW)	82.9	85.0	86.8	88.2
	(A)	140.6	144.1	147.1	149.5

RE-620B

		-5	0	5	10
25	(kW)	335.6	411.6	500.5	603.9
	(kW)	56.2	56.7	57.0	56.7
	(A)	99.6	100.3	100.6	100.3
30	(kW)	318.8	391.6	477.1	576.6
	(kW)	62.9	63.8	64.4	64.5
	(A)	109.2	110.5	111.4	111.5
35	(kW)	301.5	371.4	453.4	549.0
	(kW)	70.3	71.5	72.5	72.9
	(A)	120.4	122.4	123.8	124.5
40	(kW)	283.8	350.6	429.2	520.9
	(kW)	78.4	80.0	81.3	82.2
	(A)	133.3	135.9	138.1	139.4
45	(kW)	265.4	329.3	404.5	492.3
	(kW)	87.2	89.2	90.9	92.2
	(A)	147.7	151.1	154.0	156.0
50	(kW)	246.3	307.3	379.1	463.1
	(kW)	96.7	99.1	101.3	102.9
	(A)	163.6	167.8	171.4	174.2

RE-710B

		-5	0	5	10
25	(kW)	377.2	462.6	562.6	678.8
	(kW)	62.8	63.4	63.7	63.4
	(A)	107.3	108.3	108.7	108.3
30	(kW)	358.3	440.2	536.3	648.1
	(kW)	70.3	71.3	72.0	72.1
	(A)	120.1	121.8	122.8	123.0
35	(kW)	338.9	417.4	509.6	617.0
	(kW)	78.6	80.0	81.0	81.5
	(A)	134.2	136.6	138.3	139.2
40	(kW)	318.9	394.1	482.4	585.5
	(kW)	87.6	89.5	90.9	91.9
	(A)	149.6	152.7	155.2	156.8
45	(kW)	298.3	370.1	454.6	553.4
	(kW)	97.5	99.7	101.7	103.0
	(A)	166.4	170.3	173.5	175.9
50	(kW)	276.8	345.3	426.0	520.5
	(kW)	108.1	110.8	113.2	115.1
	(A)	184.5	189.2	193.3	196.5

RE-820B

		-5	0	5	10
25	(kW)	444.9	545.2	662.6	798.6
	(kW)	73.9	74.6	74.9	74.6
	(A)	131.6	132.6	133.0	132.6
30	(kW)	422.7	519.3	632.4	763.7
	(kW)	82.8	83.9	84.7	84.8
	(A)	144.2	145.9	147.0	147.2
35	(kW)	399.8	492.5	601.3	727.8
	(kW)	92.5	94.1	95.3	95.9
	(A)	158.9	161.5	163.4	164.3
40	(kW)	376.1	465.0	569.3	690.9
	(kW)	103.1	105.2	107.0	108.1
	(A)	175.9	179.4	182.2	184.0
45	(kW)	351.8	436.6	536.4	653.0
	(kW)	114.7	117.3	119.6	121.2
	(A)	195.1	199.6	203.5	206.3
50	(kW)	326.7	407.4	502.7	614.2
	(kW)	127.2	130.4	133.2	135.4
	(A)	216.5	222.1	227.0	230.8

RE-920B

		-5	0	5	10
25	(kW)	502.4	616.1	749.5	904.4
	(kW)	83.5	84.7	85.1	84.4
	(A)	145.2	147.1	147.7	146.7
30	(kW)	477.1	586.2	714.3	863.3
	(kW)	93.3	95.1	96.1	95.9
	(A)	160.2	163.0	164.5	164.3
35	(kW)	451.2	555.8	678.7	821.8
	(kW)	103.8	106.2	107.7	108.0
	(A)	176.9	180.8	183.3	183.9
40	(kW)	424.7	524.8	642.4	779.7
	(kW)	114.9	117.9	120.0	120.9
	(A)	195.3	200.4	204.0	205.5
45	(kW)	397.2	492.9	605.4	736.9
	(kW)	126.7	130.3	133.1	134.5
	(A)	215.4	221.7	226.4	228.9
50	(kW)	368.7	459.9	567.4	693.1
	(kW)	139.3	143.7	147.1	149.1
	(A)	237.2	244.7	250.5	254.0

RE-230A/B

)

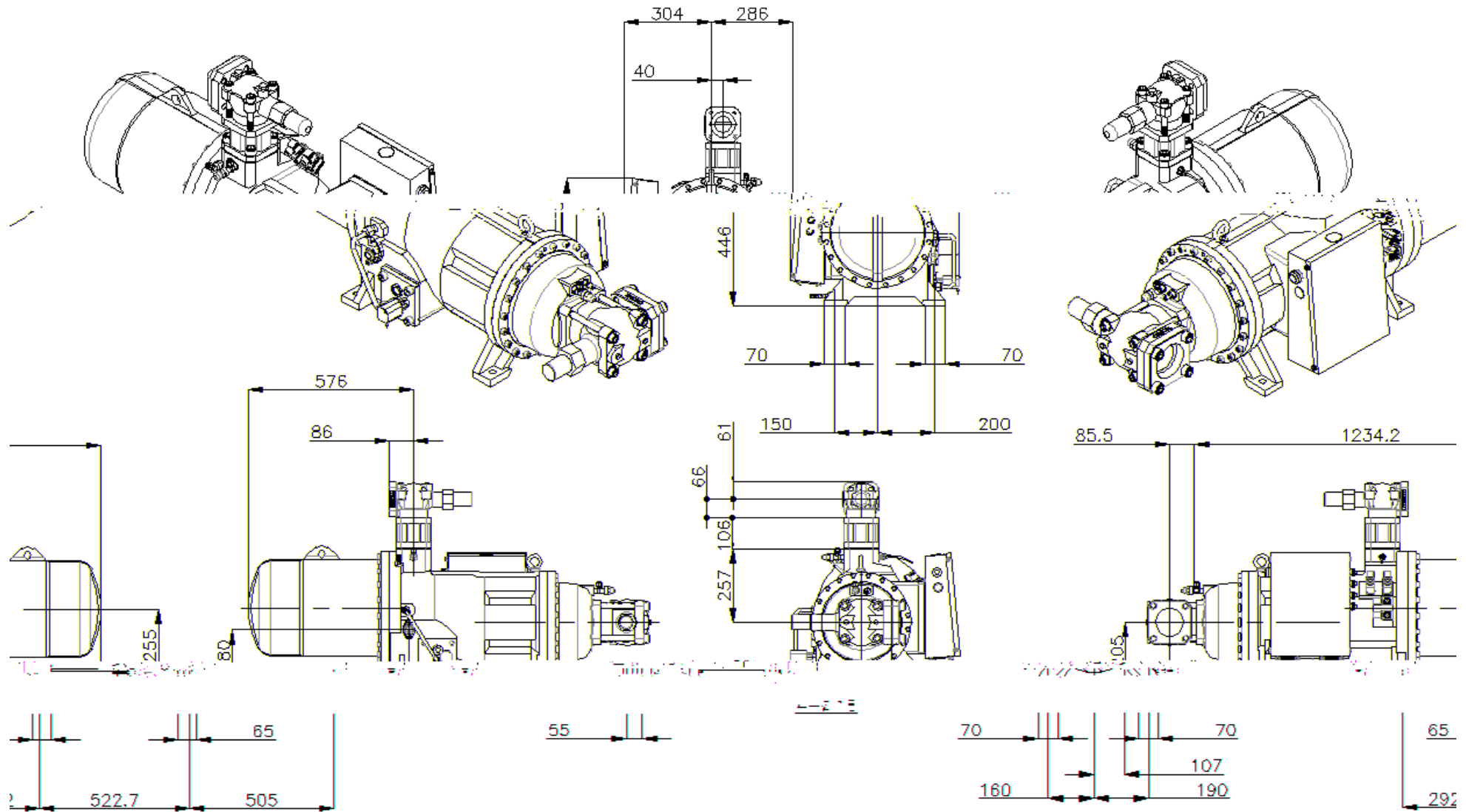

RE-260A/B

)

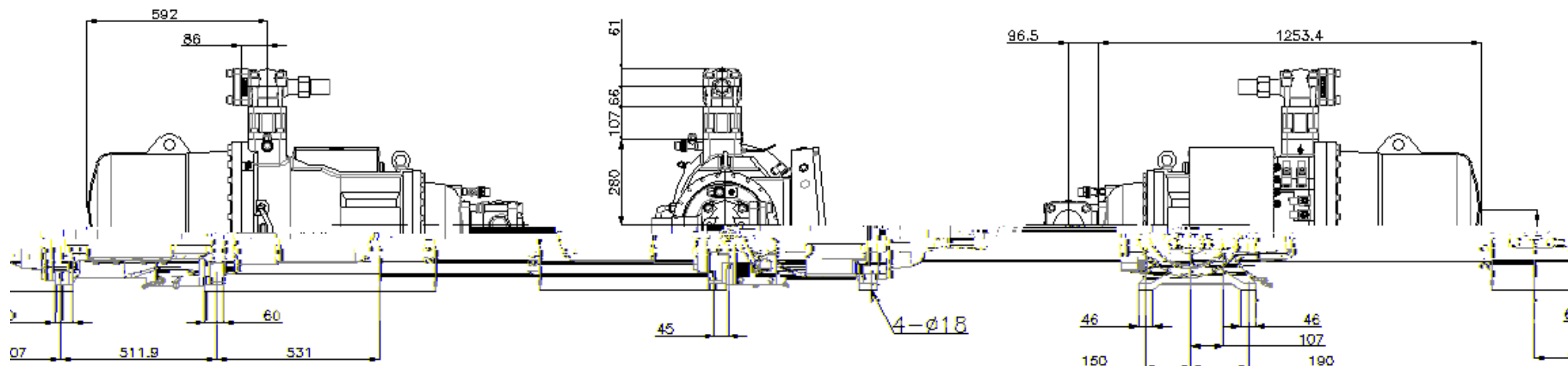
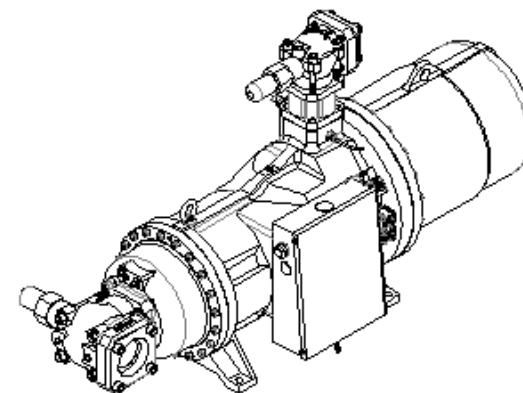
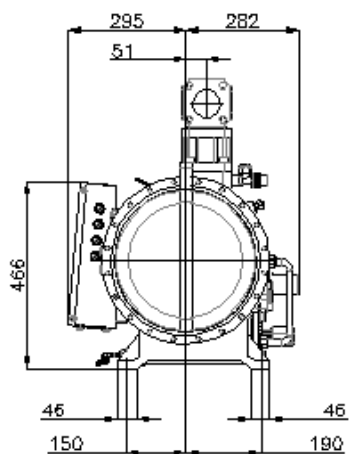
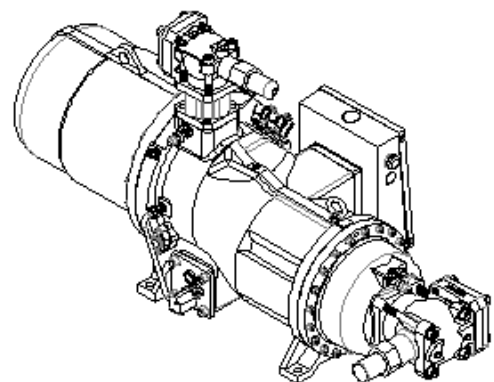

RE-300A/B

)

292.5
51 282

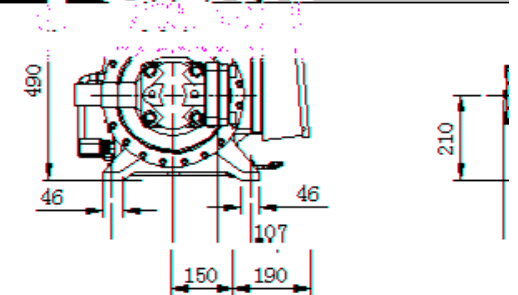
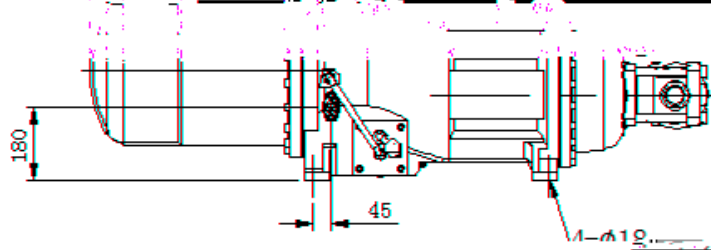
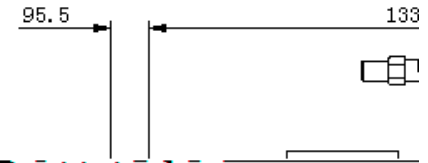
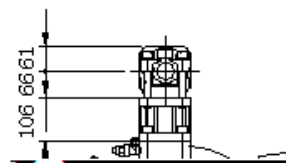
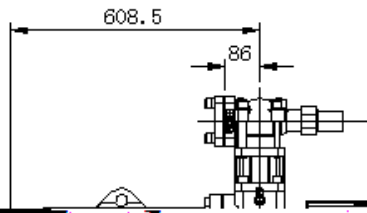
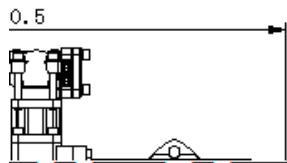
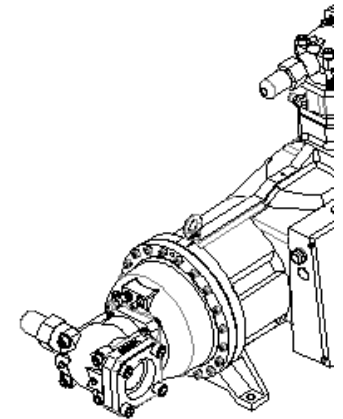
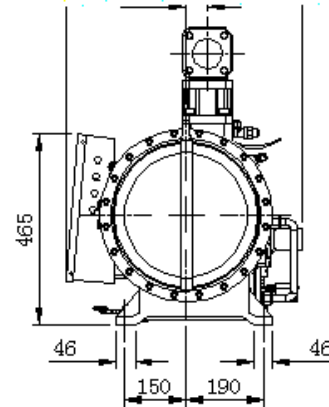
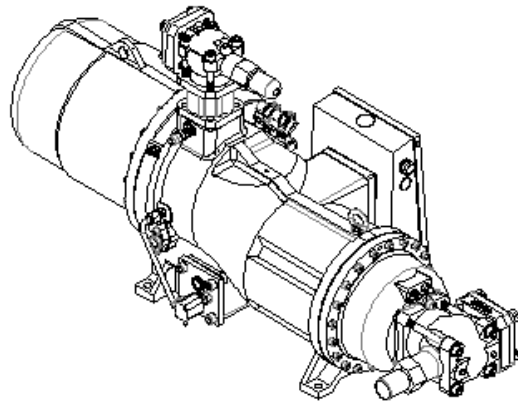
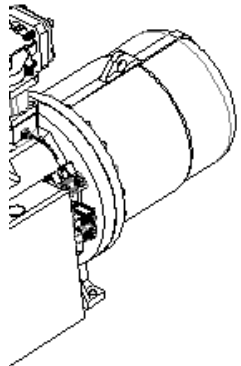

RE-420A

)

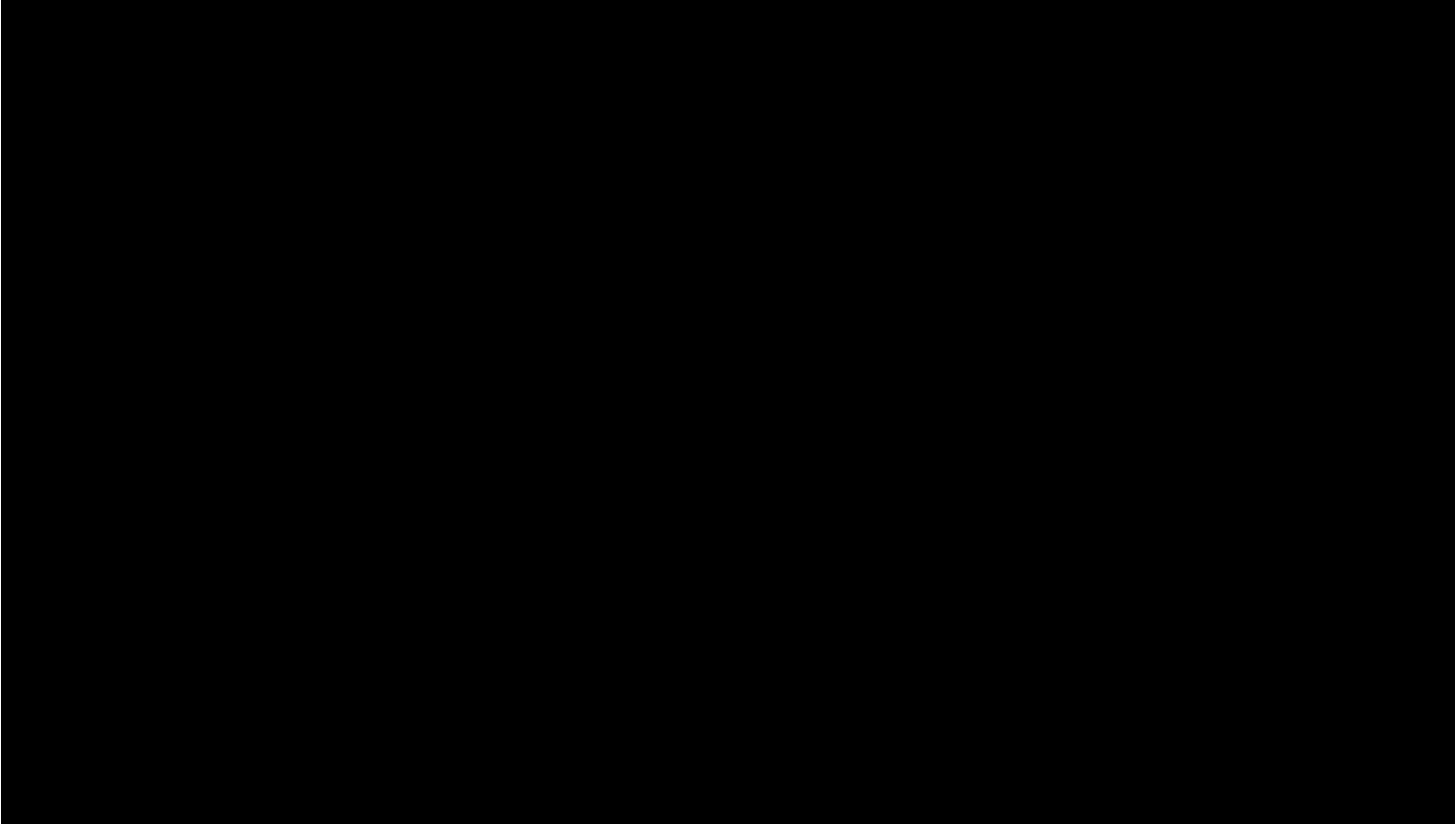

RE-420B)

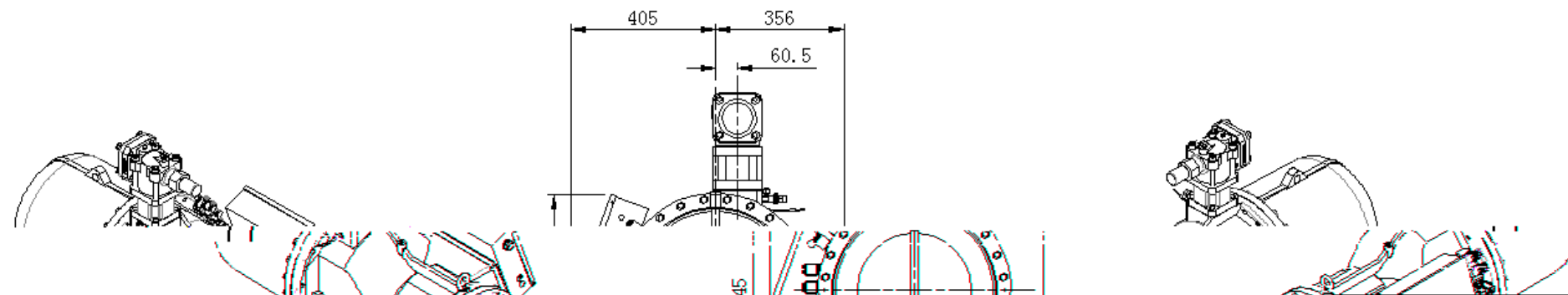

RE-480A/B)

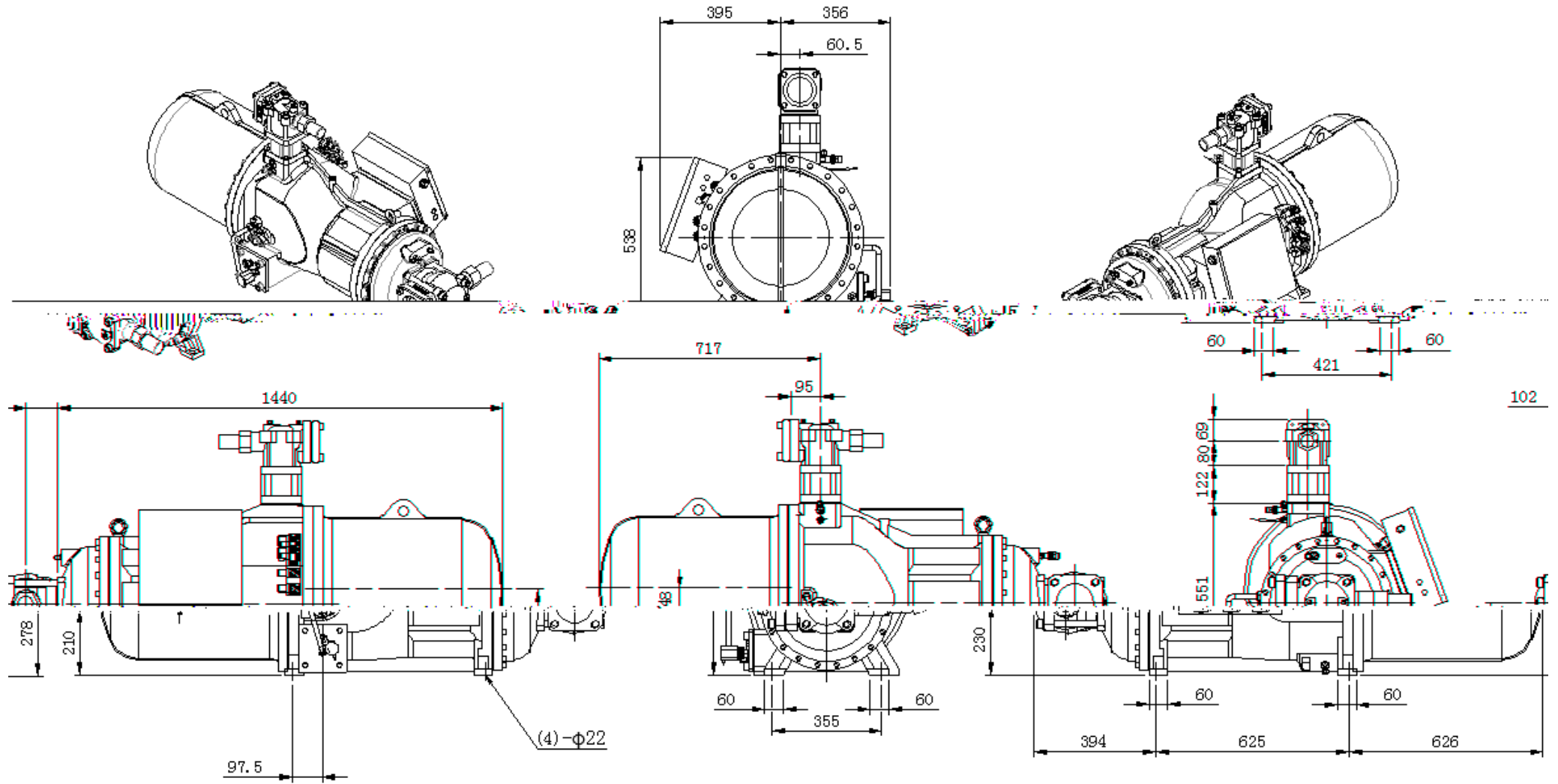

RE-550A)

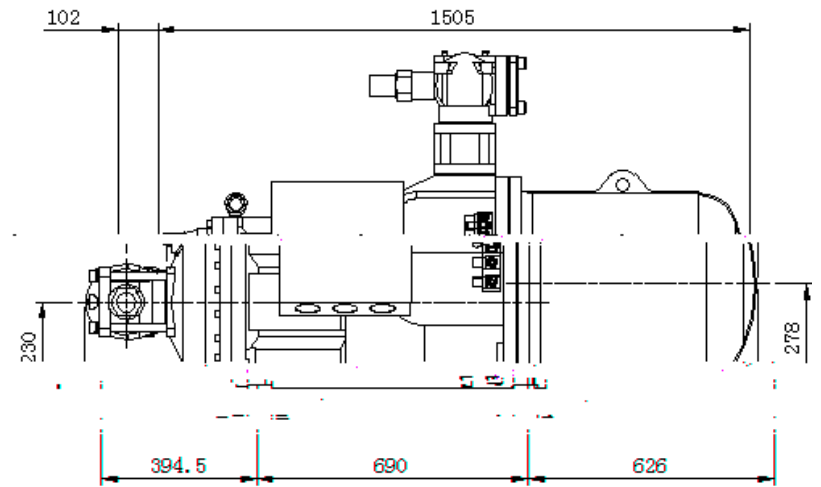
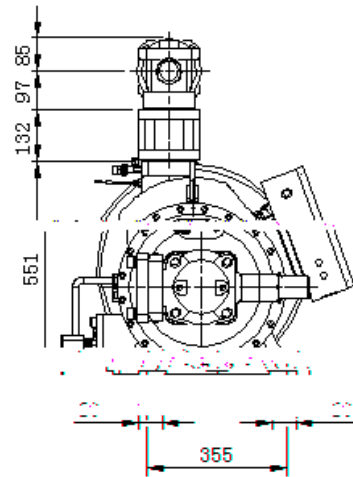
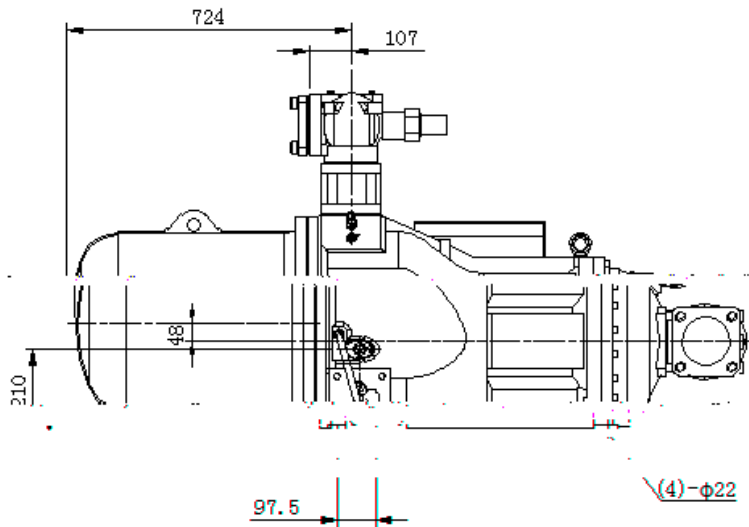
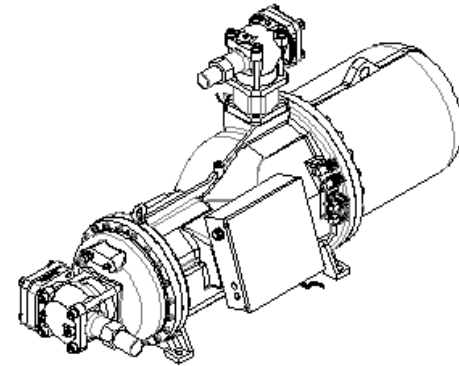
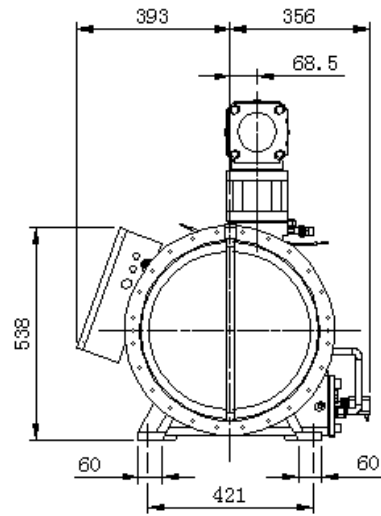
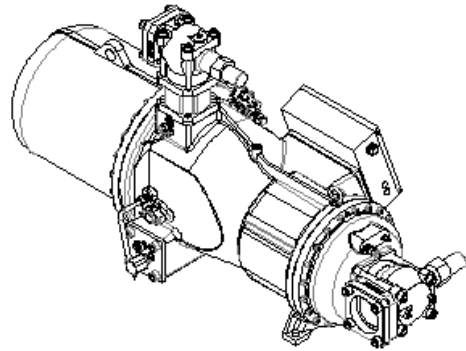

RE-550B

)

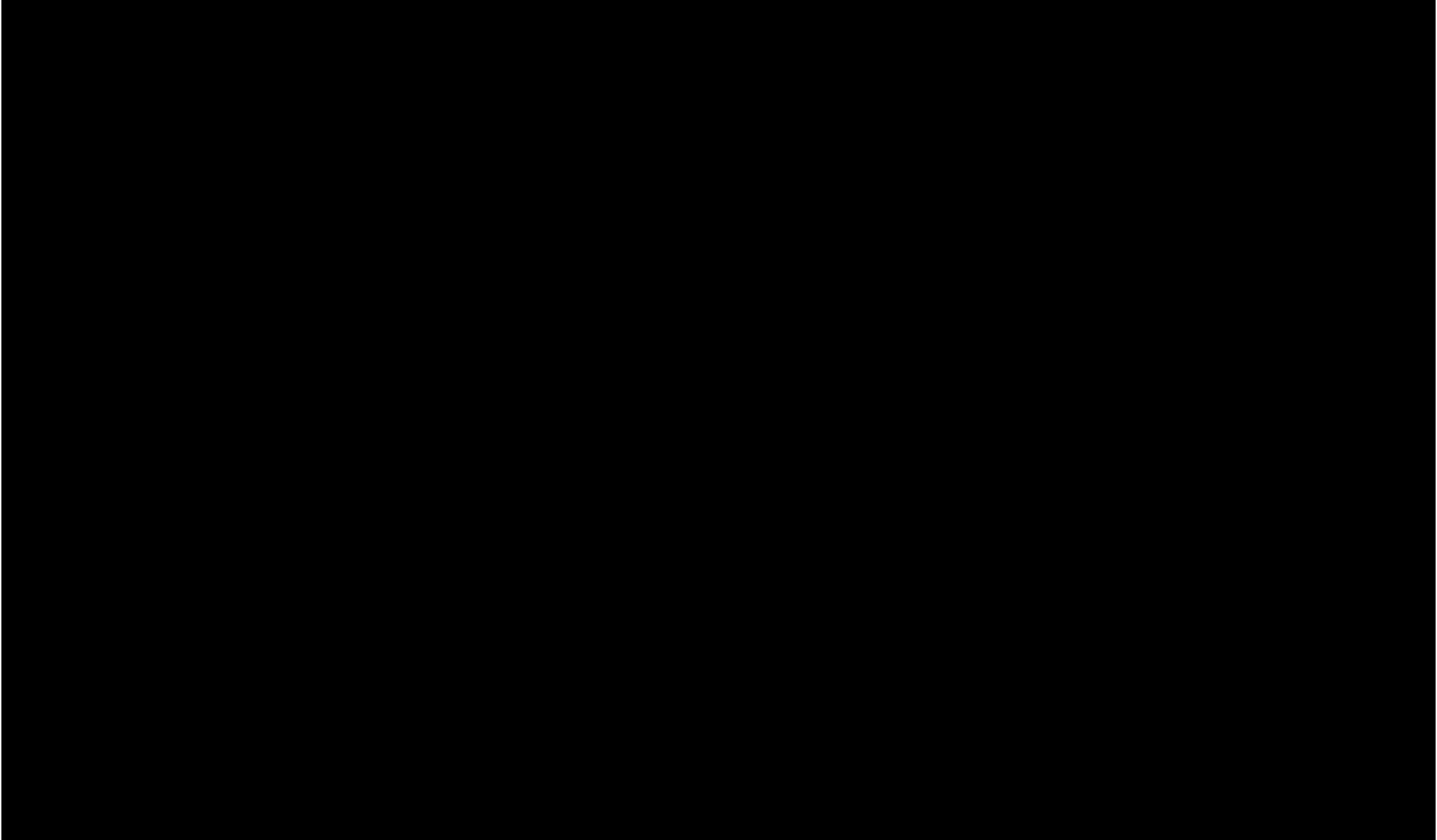

RE-620A/B

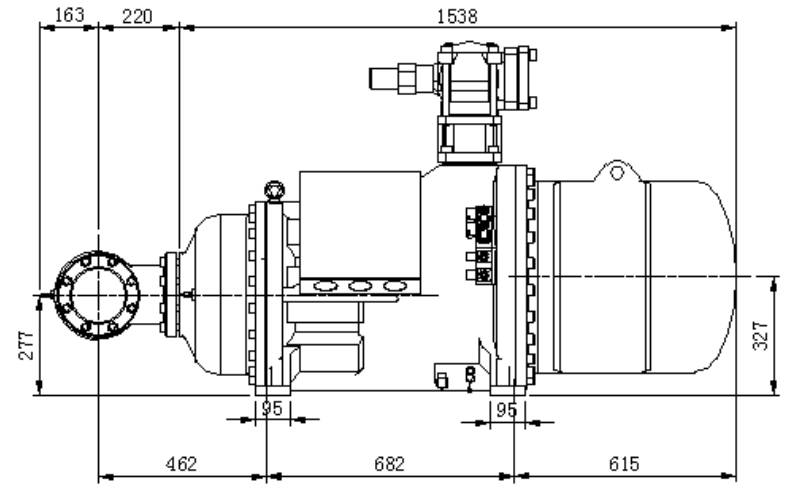
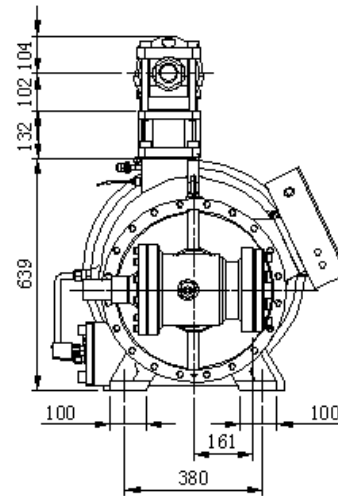
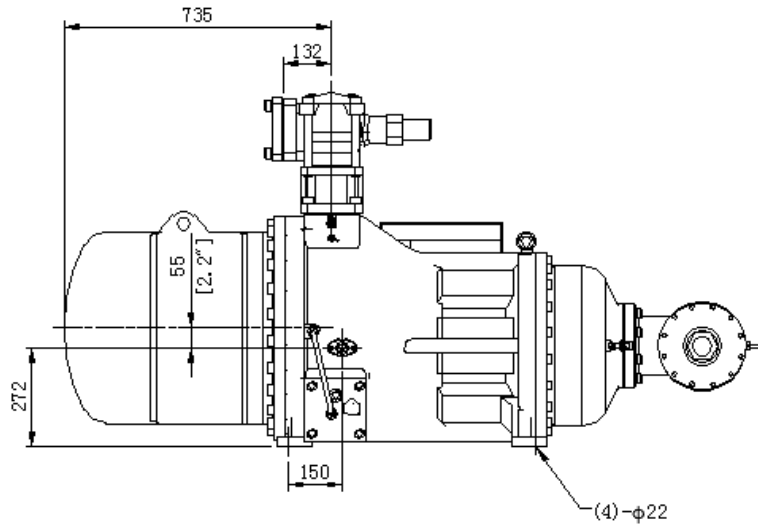
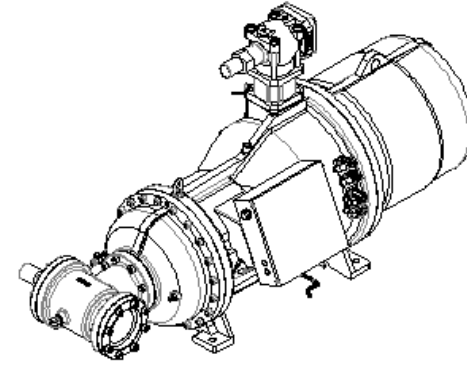
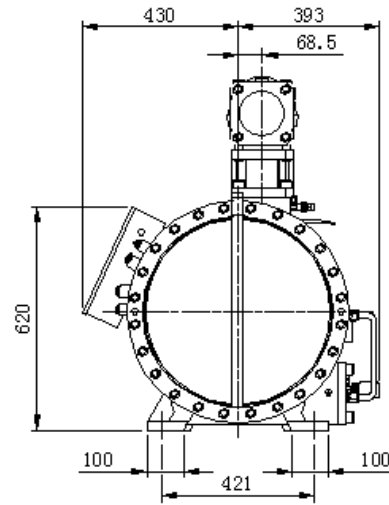
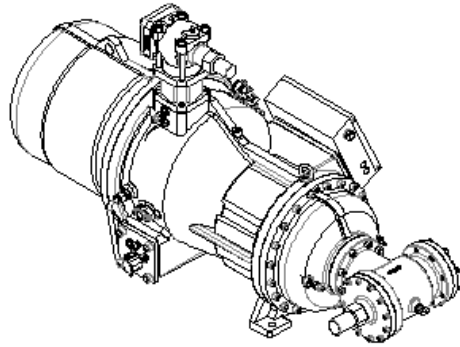

RE-820A/B

)

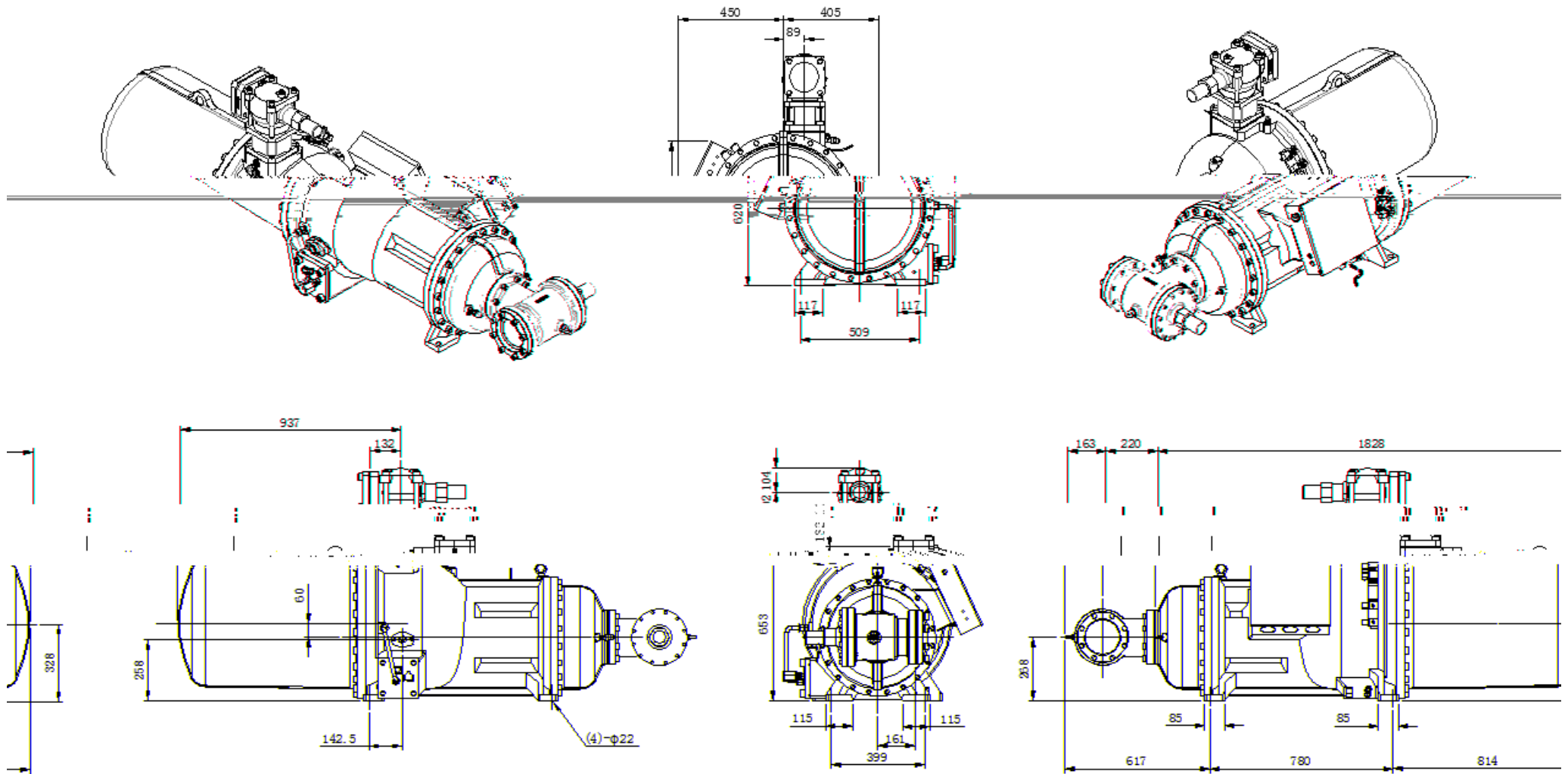

RE-920A/B

)

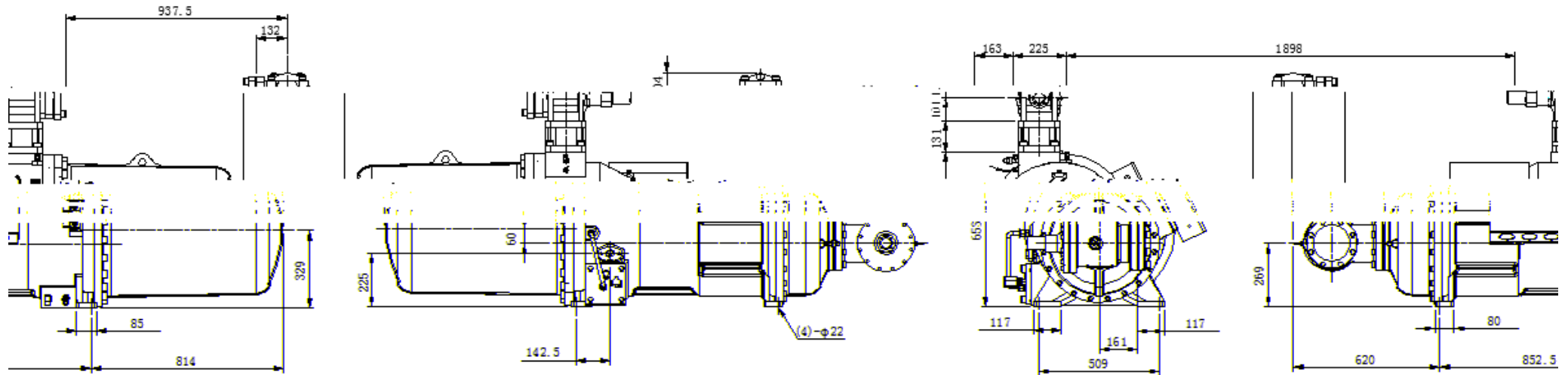
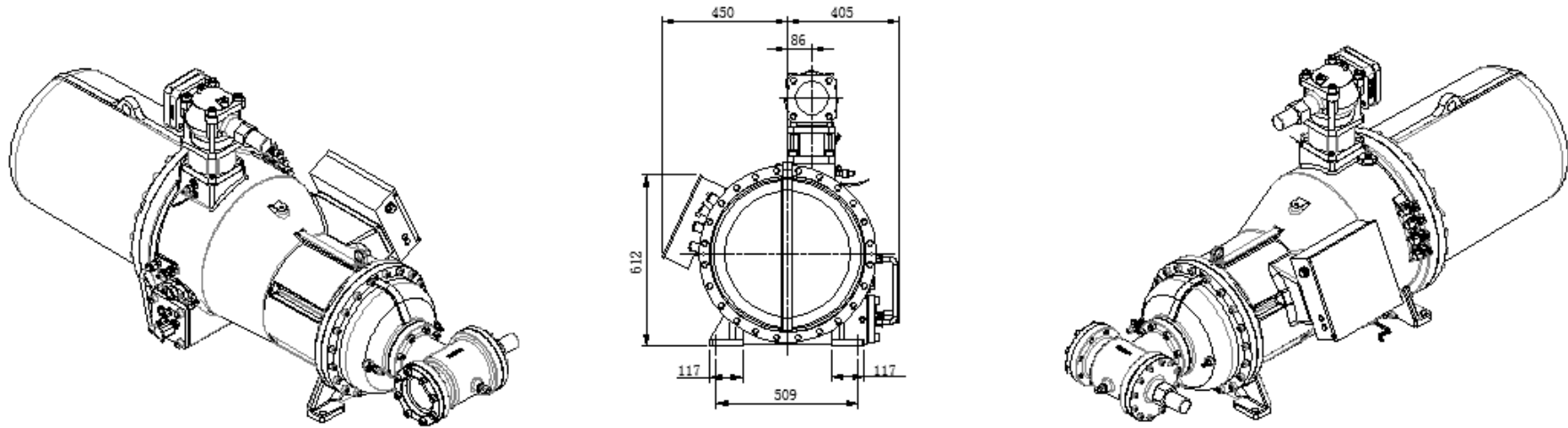

RE-230A/B

)

低压侧角阀

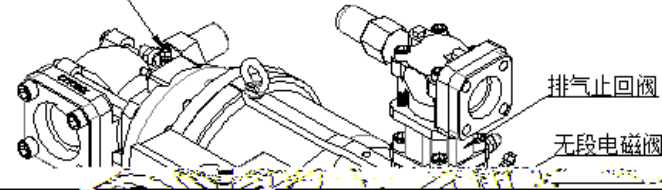

排气止回阀

无段电磁阀

吸气关断阀

排气口角阀

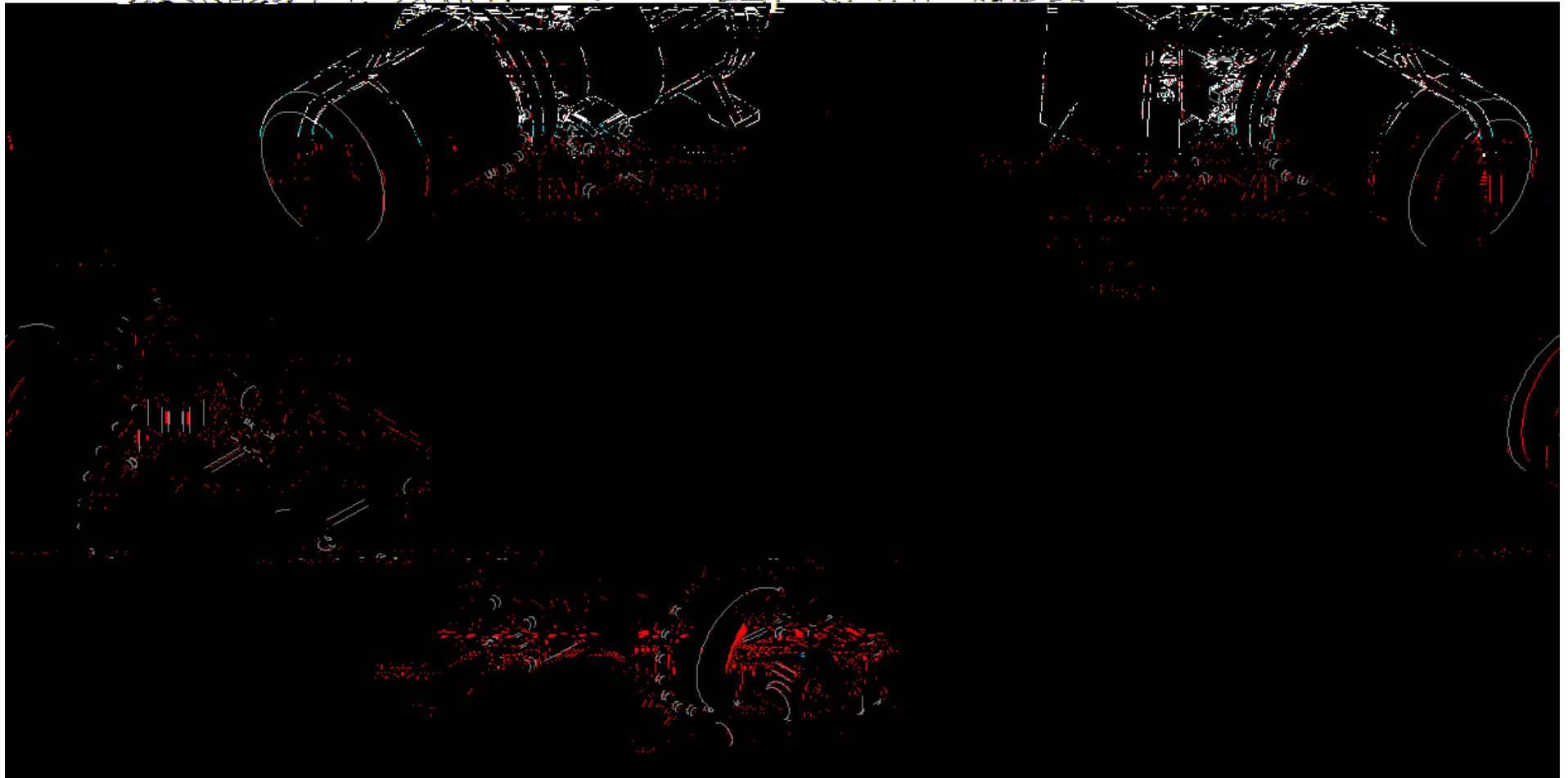
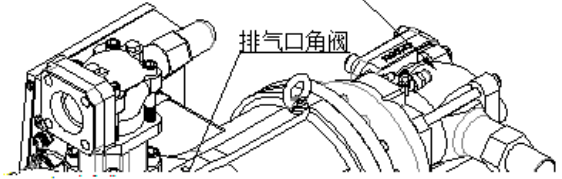

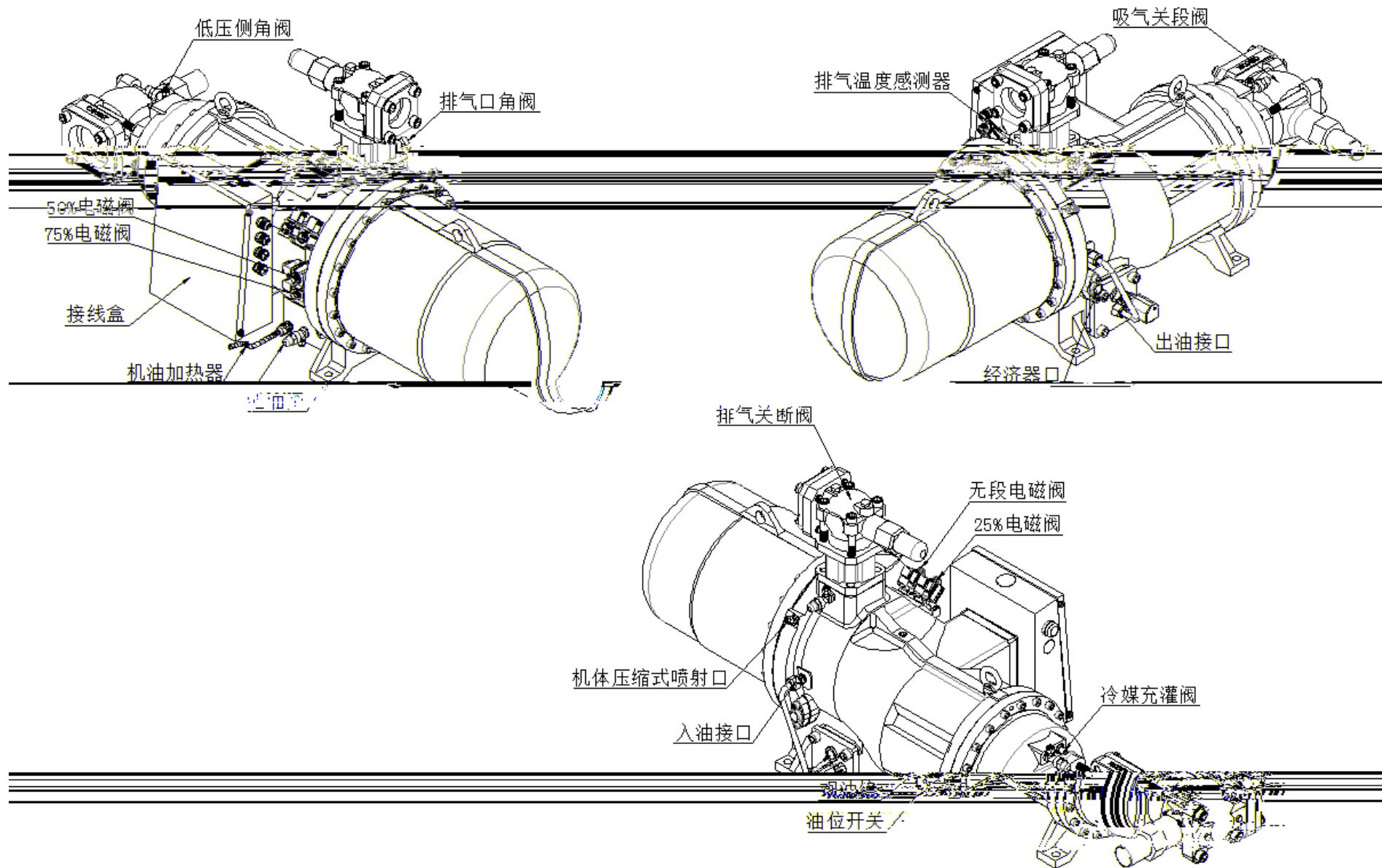

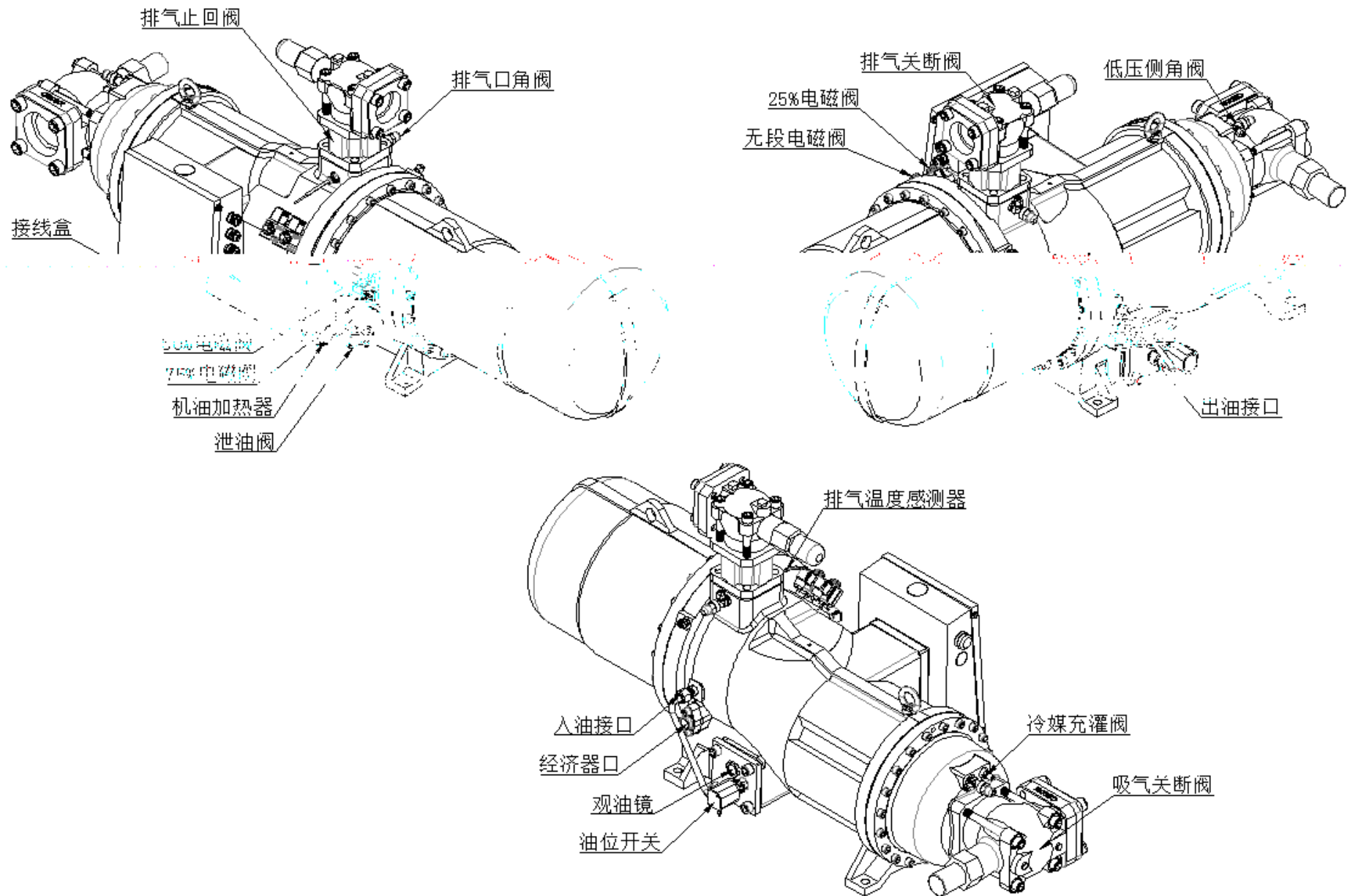

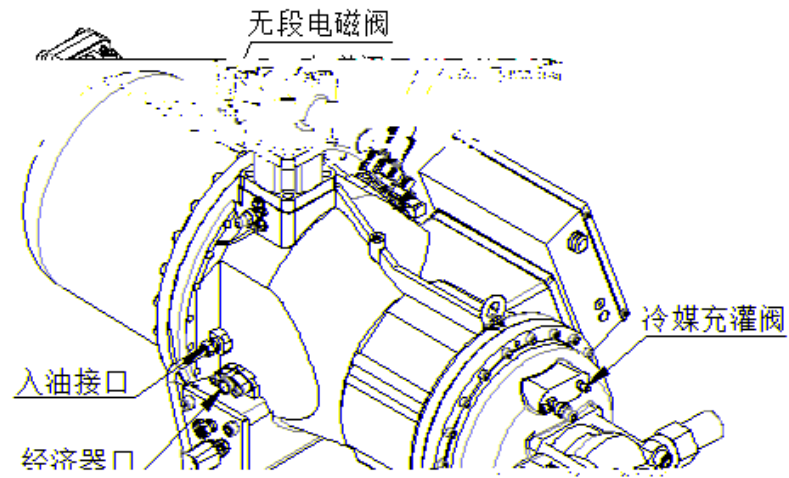
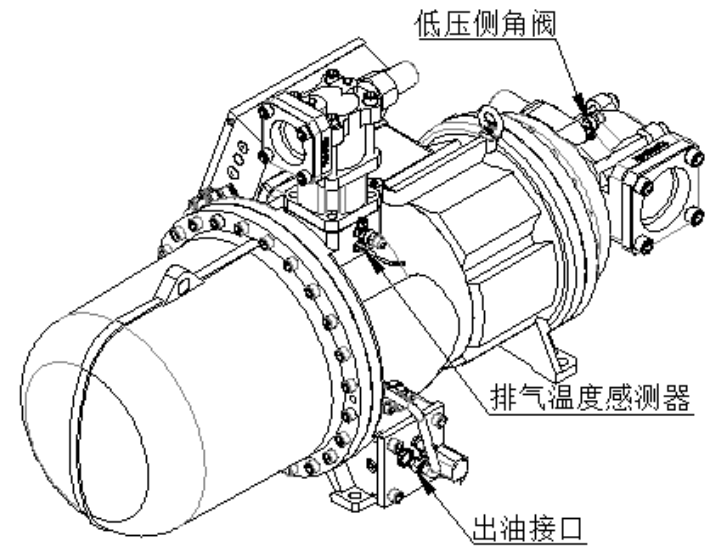
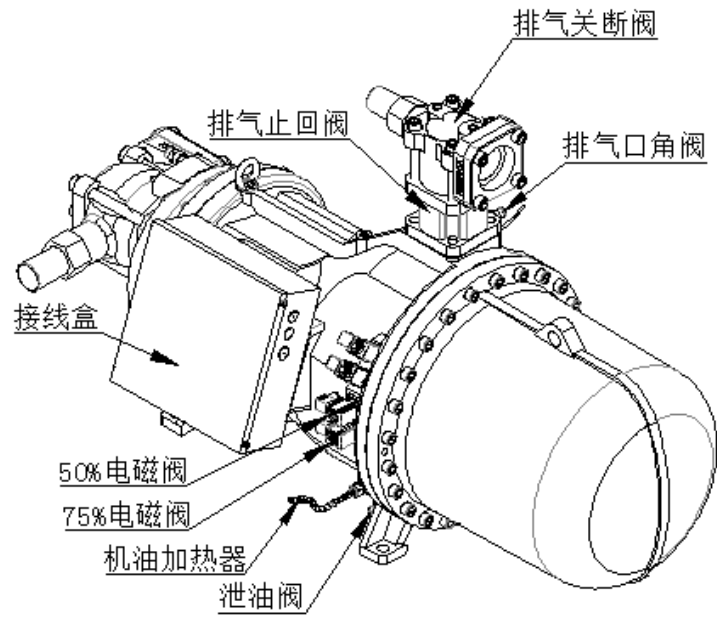

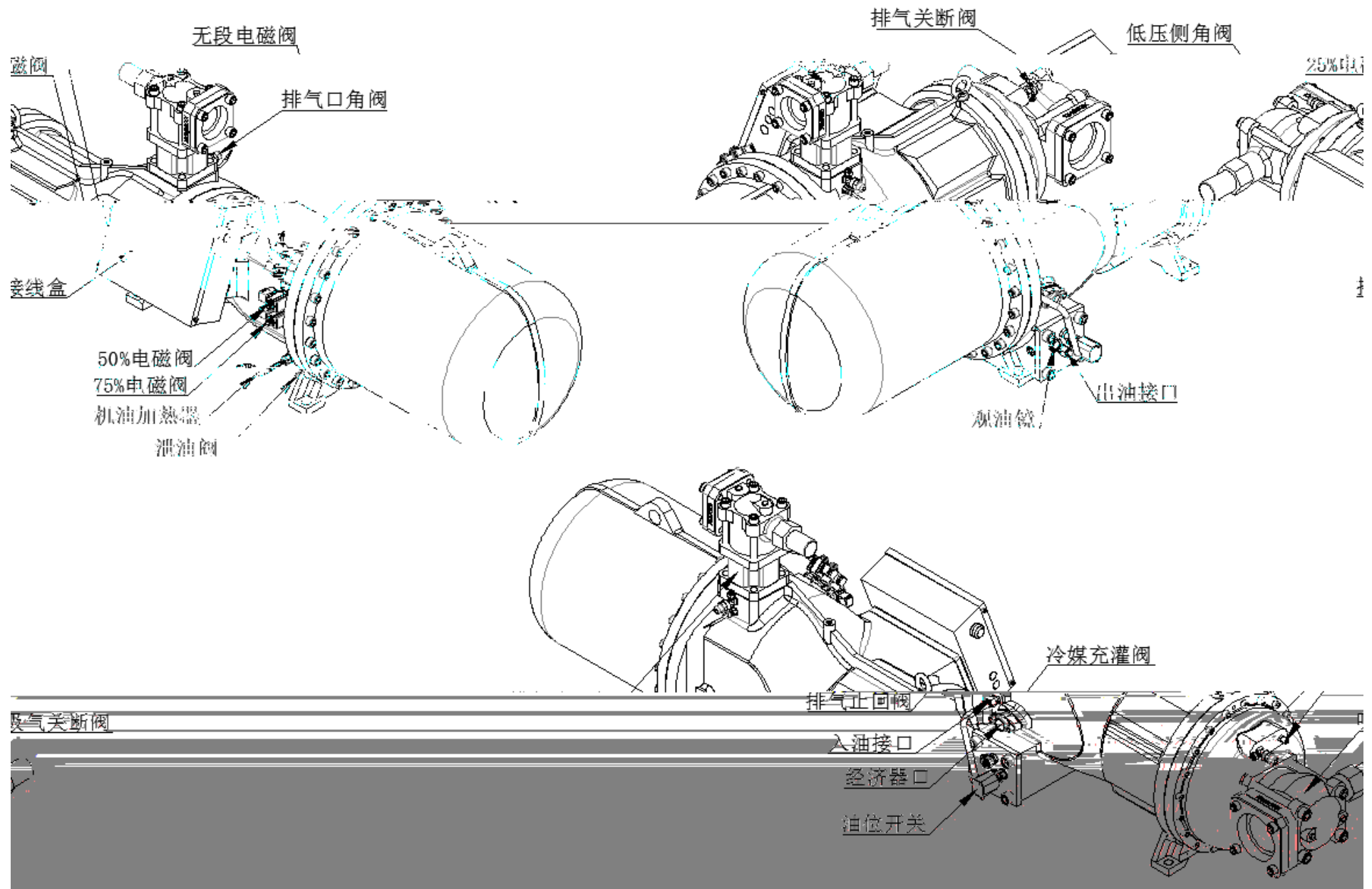

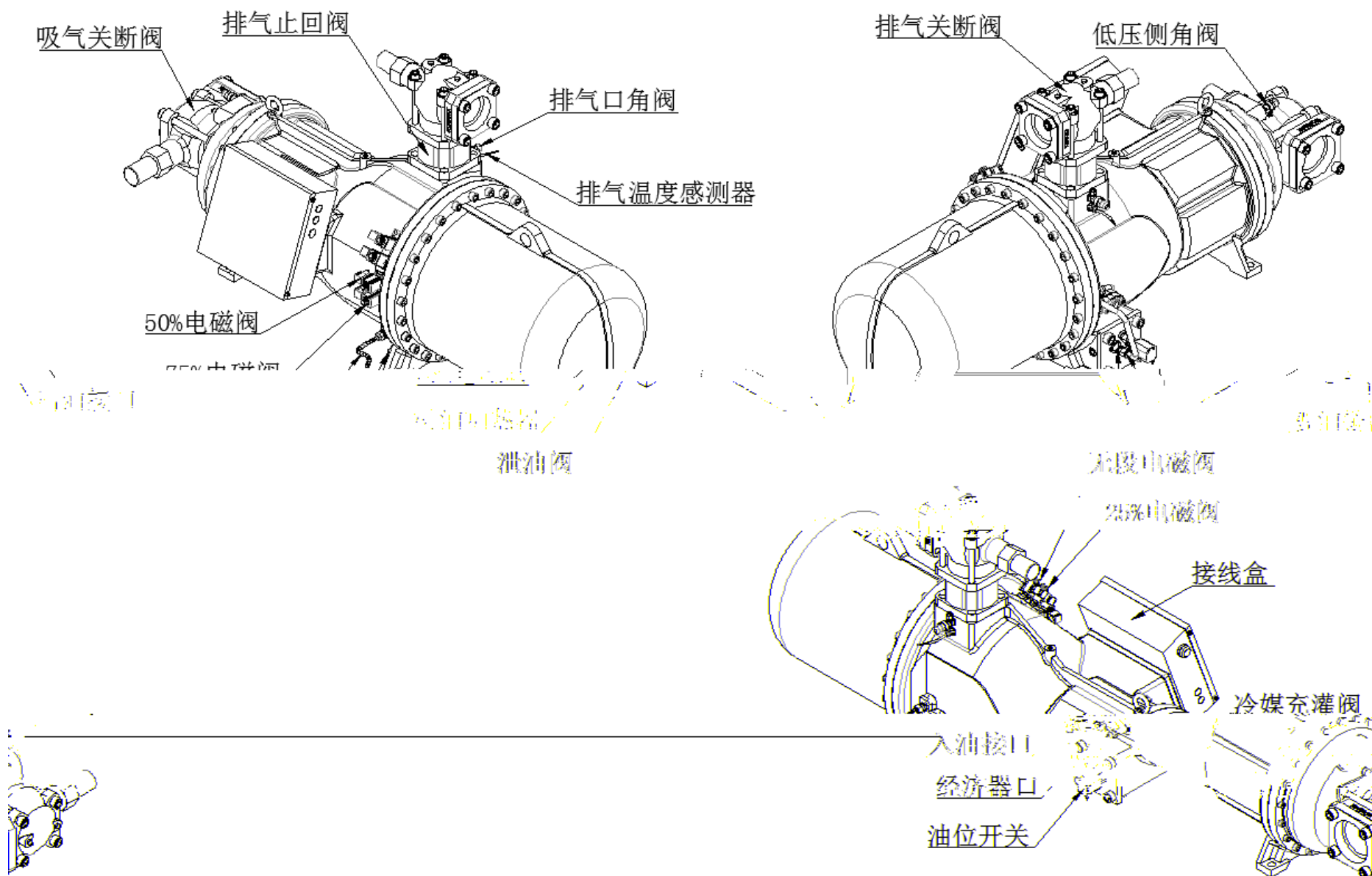

RE-620A/B

)

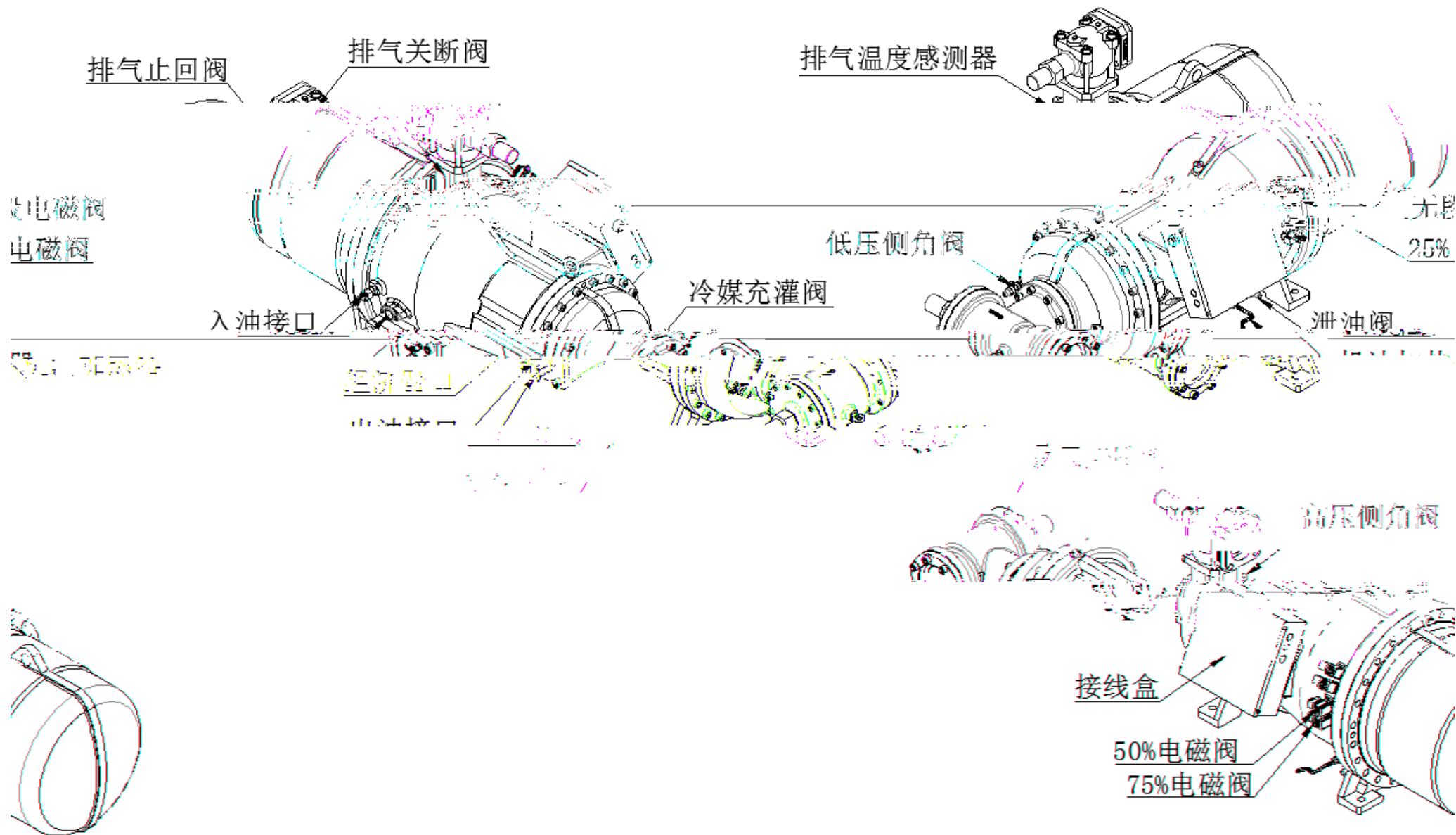

RE-820A/B

