

RC2-PZ



B1, A ,

B1, A (,



B1, A (,

1/

87 818 2.

B1, A

B1, A

B1



4/G 2.

高效

G ADKK 4 95

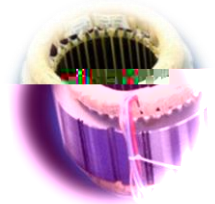

H 58GA C

H 58GA C

H 58



| | 4/G 2 | 4/G | | (| | | (4/G | | | K | | 1F | |
|----------------|----------|------|------|-------------------|-----|-----|----------|-----|---|------|-----|----|-----|
| B1, 0//, A (, | 87 | 184/ | 2-4 | 0 , 55 , 22 // | 3 2 | 27/ | E | PTC | , | 6 | 2// | 24 | 164 |
| B1, 03/, A (, | 026 | | | | | | | | | 6 | | | 17/ |
| B1, 07/, A (, | 07/ | | | | | | | | | 6 | | | 21/ |
| B1, 1//, A (, | 082 | | | | | | | | | 7 | | | 31/ |
| B1, 12/, A (, | 12/ | | | | | | | | | 03 | | | 43/ |
| B1, 15/, A (, | 146 | | | | | | | | | 03 | | | 434 |
| B1, 2//, A (, | 182 | | | | | | | | | 05 | | | 48/ |
| B1, 20/, A (, | 2/7 | | | | | | | | | 03 | | | 464 |
| B1, 23/, A (, | 228 | | | | | | | | | 05 | | | 5// |
| B1, 26/, A (, | 255 | | | | | | | | | 05 | | | 50/ |
| B1, 30/, A (, | 3/6 | | | 04 | | | | | | 62/ | | | |
| B1, 36/, A (, | 360 | | | 07 | | | | | | 7// | | | |
| B1, 40/, A (, | 4/7 | | | 1/ | | | | | | 65/ | | | |
| B1, 44/, A (, | 438 | | | 12 | | | | | | 71/ | | | |
| B1, 47/, A (, | 472 | | | 1/ | | | | | | 7/4 | | | |
| B1, 51/, A (, | 508 | | | 12 | | | | | | 74/ | | | |
| B1, 60/, A (, | 602 | | | 12 | | | | | | 0/88 | | | |
| B1, 68/, A (, | 680 | | | 17 | | | | | | 003/ | | | |
| B1, 72/, A (, | 714 | | | 17 | | | | | | 004/ | | | |
| B1, 82/, A (, | 818 | | | 17 | | | | | | 007/ | | | |
| B1, 0/1/, A (, | 0/06 | 3/ | 043/ | | | | | | | | | | |
| B1, 002/, A (, | 0011 | 3/ | 045/ | | | | | | | | | | |
| B1, 016/, A (, | 0157 | | 11// | | | | | | | | | | |

DB

| B1, 0//A, 11 | | | | | | | |
|--------------|---|-------|-------|-------|-------|-------|-------|
| | | , 3/ | , 2/ | , 1/ | , 0/ | / | 0/ |
| 2/ | (| 03-3 | 14-2 | 3/-3 | 50-3 | 78-8 | 016-5 |
| | (| 02-8 | 04-/ | 05-3 | 06-7 | 08-/ | 08-6 |
| | (| 16-1 | 17-5 | 2/-4 | 21-3 | 23-/ | 24-0 |
| | B | 0-/30 | 0-575 | 1-354 | 2-345 | 3-630 | 5-361 |
| 3/ | (| 01-0 | 10-0 | 24-0 | 43-0 | 7/-2 | 003-8 |
| | (| 05-6 | 07-/ | 08-4 | 10-1 | 11-6 | 12-7 |
| | (| 2/-8 | 21-5 | 23-7 | 26-1 | 28-2 | 30-/ |
| | B | /-617 | 0-063 | 0-684 | 1-444 | 2-431 | 3-72/ |
| 4/ | (| 02-2 | 12-4 | 26-8 | 47-0 | 74-1 | 010-3 |
| | (| 04-1 | 05-3 | 06-8 | 08-3 | 1/-6 | 10-5 |
| | (| 17-8 | 2/-4 | 21-4 | 23-5 | 25-4 | 26-7 |
| | B | /-764 | 0-318 | 1-005 | 1-883 | 3-004 | 4-500 |
| 5/ | (| ,, | ,, | ,, | 24-0 | 45-1 | 73-3 |
| | (| ,, | ,, | ,, | 2/-/ | 21-4 | 23-5 |
| | (| ,, | ,, | ,, | 4/-6 | 43-6 | 47-2 |
| | B | ,, | ,, | ,, | 0-057 | 0-621 | 1-327 |

| B1, 03/A, 11 | | | | | | | |
|--------------|---|-------|-------|-------|-------|-------|-------|
| | | , 3/ | , 2/ | , 1/ | , 0/ | / | 0/ |
| 2/ | (| 1/-/ | 24-0 | 44-8 | 73-8 | 013-1 | 065-1 |
| | (| 07-2 | 08-7 | 10-6 | 12-4 | 14-0 | 15-0 |
| | (| 25-0 | 27-0 | 3/-4 | 32-/ | 34-0 | 35-4 |
| | B | 0-/81 | 0-658 | 1-47/ | 2-501 | 3-845 | 5-654 |
| 3/ | (| 05-8 | 18-1 | 37-5 | 63-8 | 00/-8 | 047-6 |
| | (| 11-/ | 12-6 | 14-7 | 17-/ | 2/-/ | 20-3 |
| | (| 30-/ | 32-2 | 35-1 | 38-2 | 41-0 | 43-2 |
| | B | /-654 | 0-120 | 0-771 | 1-563 | 2-6/1 | 4-/38 |
| 4/ | (| 02-3 | 12-7 | 3/-/ | 52-1 | 84-3 | 028-2 |
| | (| 15-2 | 17-2 | 2/-7 | 22-3 | 24-8 | 27-/ |
| | (| 35-7 | 38-6 | 42-2 | 46-2 | 50-0 | 53-3 |
| | B | /-4/8 | /-731 | 0-187 | 0-780 | 1-546 | 2-554 |
| 5/ | (| ,, | ,, | ,, | 37-6 | 66-8 | 005-6 |
| | (| ,, | ,, | ,, | 28-6 | 31-8 | 34-6 |
| | (| ,, | ,, | ,, | 56-0 | 61-2 | 66-/ |
| | B | ,, | ,, | ,, | 0-114 | 0-705 | 1-441 |

| B1, 07/A, 11 | | | | | | | |
|--------------|---|-------|-------|-------|-------|-------|-------|
| | | , 3/ | , 2/ | , 1/ | , 0/ | / | 0/ |
| 2/ | (| 15-3 | 35-1 | 62-6 | 000-3 | 052-/ | 120-2 |
| | (| 12-/ | 13-8 | 16-1 | 18-4 | 20-4 | 21-6 |
| | (| 36-0 | 38-4 | 41-3 | 44-3 | 47-0 | 48-7 |
| | B | 0-035 | 0-744 | 1-60/ | 2-666 | 4-071 | 6-/62 |
| 3/ | (| 11-2 | 28-4 | 53-/ | 87-3 | 034-5 | 1/7-2 |
| | (| 16-6 | 18-7 | 21-3 | 24-1 | 26-5 | 28-4 |
| | (| 42-/ | 44-7 | 48-3 | 52-0 | 55-5 | 58-2 |
| | B | /-7/3 | 0-212 | 0-862 | 1-688 | 2-760 | 4-168 |
| 4/ | (| 06-6 | 20-3 | 41-6 | 72-1 | 014-3 | 071-7 |
| | (| 22-/ | 24-4 | 27-5 | 30-8 | 34-0 | 36-6 |
| | (| 5/-0 | 52-5 | 57-0 | 61-8 | 66-5 | 70-4 |
| | B | /-426 | /-773 | 0-254 | 0-871 | 1-670 | 2-720 |
| 5/ | (| ,, | ,, | ,, | 54-4 | 0/1-5 | 042-3 |
| | (| ,, | ,, | ,, | 38-8 | 42-8 | 46-3 |
| | (| ,, | ,, | ,, | 73-7 | 80-0 | 85-7 |
| | B | ,, | ,, | ,, | 0-203 | 0-8/3 | 1-561 |

| B1, 1//A, 11 | | | | | | | |
|--------------|---|-------|-------|-------|-------|-------|-------|
| | | , 3/ | , 2/ | , 1/ | , 0/ | / | 0/ |
| 2/ | (| 17-2 | 38-5 | 67-8 | 008-6 | 064-0 | 137-5 |
| | (| 14-2 | 16-3 | 18-8 | 21-4 | 23-5 | 25-/ |
| | (| 4-/ | 41-6 | 45-/ | 48-3 | 51-3 | 53-2 |
| | B | 0-005 | 0-7/7 | 1-525 | 2-576 | 4-/48 | 5-8/4 |
| 3/ | (| 12-7 | 31-1 | 57-6 | 0/4-6 | 045-4 | 112-7 |
| | (| 2/-4 | 21-7 | 24-6 | 27-6 | 30-3 | 32-3 |
| | (| 45-6 | 48-8 | 52-8 | 57-1 | 61-0 | 64-0 |
| | B | /-672 | 0-177 | 0-813 | 1-620 | 2-668 | 4-043 |
| 4/ | (| 07-8 | 22-6 | 45-4 | 78-1 | 023-6 | 085-3 |
| | (| 25-2 | 28-0 | 31-4 | 35-1 | 38-5 | 41-4 |
| | (| 53-6 | 57-6 | 62-6 | 68-1 | 73-4 | 78-/ |
| | B | /-411 | /-750 | 0-218 | 0-822 | 1-602 | 2-630 |
| 5/ | (| ,, | ,, | ,, | 57-6 | 00/-/ | 053-6 |
| | (| ,, | ,, | ,, | 43-8 | 48-2 | 52-1 |
| | (| ,, | ,, | ,, | 81-6 | 88-8 | 0/5-3 |
| | B | ,, | ,, | ,, | 0-142 | 0-746 | 1-5/6 |

| | | | | | | | |
|--------------|---|------|------|-------|------|---|----|
| B1, 2//A, 11 | | | | | | | |
| | | , 3/ | , 2/ | , 1/ | , 0/ | / | 0/ |
| | (| 33-7 | 67-4 | 013-7 | | | |

2/

| B1, 23/A, 11 | | | | | | | |
|--------------|---|-------|--------|--------|--------|--------|--------|
| | | , 3/ | , 2/ | , 1/ | , 0/ | / | 0/ |
| 2/ | (| 41-7 | 81-3 | 035-7 | 110-8 | 213-7 | 35/-8 |
| | (| 32-5 | 36-1 | 40-4 | 44-8 | 48-5 | 51-/- |
| | (| 70-6 | 75-7 | 82-0 | 88-4 | 0/4-0 | 0/7-6 |
| | B | 0-10/ | 0-847 | 1-74/ | 2-861 | 4-34/ | 6-328 |
| 3/ | (| 33-5 | 68-0 | 016-7 | 085-7 | 18/-0 | 304-/- |
| | (| 41-3 | 45-4 | 50-3 | 55-5 | 60-2 | 63-7 |
| | (| 83-3 | 0// -3 | 0/6-8 | 004-7 | 012-0 | 017-4 |
| | B | /-740 | 0-3/0 | 1-/-70 | 1-845 | 3-/-61 | 4-441 |
| 4/ | (| 24-4 | 51-8 | 0/4-6 | 055-0 | 14/-1 | 253-1 |
| | (| 51-3 | 56-2 | 62-1 | 68-4 | 74-3 | 8/-3 |
| | (| 0/8-4 | 005-8 | 015-0 | 025-/- | 034-4 | 042-3 |
| | B | /-458 | /-824 | 0-333 | 1-/-8/ | 1-818 | 3-/-2/ |
| 5/ | (| ,, | ,, | ,, | 020-2 | 1/3-8 | 2/5-/- |
| | (| ,, | ,, | ,, | 83-3 | 0/1-/- | 0/7-7 |
| | (| ,, | ,, | ,, | 05/-0 | 061-6 | 073-1 |
| | B | ,, | ,, | ,, | 0-280 | 1-/-/8 | 1-703 |

| B1, 26/A, 11 | | | | | | | |
|--------------|---|-------|-------|--------|--------|--------|--------|
| | | , 3/ | , 2/ | , 1/ | , 0/ | / | 0/ |
| 2/ | (| 45-7 | 88-4 | 047-0 | 128-/- | 238-7 | 385-3 |
| | (| 36-2 | 40-1 | 44-8 | 5/-5 | 53-6 | 56-1 |
| | (| 76-/- | 81-5 | 88-5 | 0/5-6 | 001-8 | 005-7 |
| | B | 0-1// | 0-832 | 1-718 | 2-832 | 4-30/ | 6-273 |
| 3/ | (| 37-/- | 74-0 | 026-5 | 101-/- | 201-4 | 336-/- |
| | (| 45-8 | 50-2 | 55-6 | 61-1 | 66-2 | 70-0 |
| | (| 0/0-0 | 0/6-6 | 004-8 | 013-5 | 021-5 | 027-5 |
| | B | /-733 | 0-278 | 1-/-54 | 1-823 | 3-/-31 | 4-400 |
| 4/ | (| 27-1 | 56-6 | 002-6 | 067-8 | 158-3 | 281-2 |
| | (| 56-6 | 62-/- | 68-3 | 75-1 | 81-6 | 87-0 |
| | (| 006-5 | 014-7 | 024-8 | 035-6 | 046-1 | 055-/- |
| | B | /-453 | /-816 | 0-321 | 1-/-63 | 1-8/6 | 3-/// |
| 5/ | (| ,, | ,, | ,, | 030-2 | 11/-5 | 218-5 |
| | (| ,, | ,, | ,, | 0/1-4 | 00/-6 | 007-/- |
| | (| ,, | ,, | ,, | 062-3 | 076-5 | 1// -5 |
| | B | ,, | ,, | ,, | 0-268 | 0-882 | 1-682 |

| B1, 30/A, 11 | | | | | | | |
|--------------|---|------|--------|-------|-------|--------|-------|
| | | , 3/ | , 2/ | , 1/ | , 0/ | / | 0/ |
| | (| 50-6 | 0/7-0 | 060-8 | 148-8 | 27/-2 | 428-7 |
| 2/ | (| 41-0 | 45-3 | 50-5 | 55-7 | 60-2 | 63-0 |
| | (| 83-0 | 0// -0 | 0/6-4 | 004-1 | 011- / | |

| B1, 40/A, 11 | | | | | | | |
|--------------|---|-------|--------|-------|-------|--------|--------|
| | | , 3/ | , 2/ | , 1/ | , 0/ | / | 0/ |
| 2/ | (| 67-4 | 026-4 | 107-1 | 218-8 | 371-7 | 574-1 |
| | (| 52-8 | 58-0 | 64-4 | 70-7 | 76-2 | 8/-7 |
| | (| 008-6 | 015-5 | 024-1 | 033-1 | 041-0 | 046-1 |
| | B | 0-118 | 0-878 | 1-781 | 3-/20 | 4-42/ | 6-438 |
| 3/ | (| 55-3 | 006-7 | 08/-1 | 181-5 | 320-2 | 506-/- |
| | (| 65-7 | 71-6 | 8/-/ | 86-4 | 0/3-3 | 0/8-4 |
| | (| 026-0 | 034-4 | 045-0 | 056-4 | 067-0 | 075-1 |
| | B | /-753 | 0-313 | 1-002 | 1-888 | 3-021 | 4-523 |
| 4/ | (| 42-/- | 82-5 | 046-3 | 136-0 | 261-0 | 430-3 |
| | (| 80-4 | 87-4 | 0/6-1 | 005-3 | 014-0 | 021-3 |
| | (| 047-2 | 058-/- | 071-4 | 086-1 | 100-4 | 112-3 |
| | B | /-468 | /-84/ | 0-357 | 1-012 | 1-862 | 3-/-78 |
| 5/ | (| ,, | ,, | ,, | 084-4 | 2/3-8 | 344-0 |
| | (| ,, | ,, | ,, | 027-2 | 038-4 | 048-2 |
| | (| ,, | ,, | ,, | 122-2 | 141-/- | 157-5 |
| | B | ,, | ,, | ,, | 0-302 | 1-/-3/ | 1-746 |

| B1, 44/A, 11 | | | | | | | |
|--------------|---|-------|-------|--------|--------|--------|--------|
| | | , 3/ | , 2/ | , 1/ | , 0/ | / | 0/ |
| 2/ | (| 75-6 | 040-8 | 130-2 | 253-8 | 422-8 | 646-7 |
| | (| 60-8 | 66-7 | 73-8 | 81-0 | 87-1 | 0/1-0 |
| | (| 02/-2 | 027-3 | 037-5 | 048-1 | 057-4 | 063-5 |
| | B | 0-1/5 | 0-841 | 1-732 | 2-851 | 4-325 | 6-31/ |
| 3/ | (| 62-2 | 02/-/ | 10/-0 | 212-5 | 366-/- | 571-2 |
| | (| 75-3 | 82-0 | 0/0-1 | 0/8-7 | 006-4 | 012-1 |
| | (| 04/-7 | 05/-6 | 062-1 | 075-5 | 087-8 | 1/7-2 |
| | B | /-737 | 0-286 | 1-/-65 | 1-837 | 3-/-50 | 4-427 |
| 4/ | (| 47-3 | 0/2-3 | 062-6 | 162-0 | 300-2 | 487-7 |
| | (| 0/1-8 | 00/-8 | 01/-5 | 020-/- | 03/-7 | 038-/- |
| | (| 064-7 | 077-3 | 1/3-0 | 110-0 | 126-4 | 140-0 |
| | B | /-457 | /-821 | 0-33/ | 1-/-74 | 1-810 | 3-/-08 |
| 5/ | (| ,, | ,, | ,, | 104-7 | 225-8 | 4/2-0 |
| | (| ,, | ,, | ,, | 044-6 | 057-1 | 068-2 |
| | (| ,, | ,, | ,, | 151-4 | 172-6 | 2/1-6 |
| | B | ,, | ,, | ,, | 0-276 | 1-/-/2 | 1-7/6 |

| B1, 47/A, 11 | | | | | | | |
|--------------|---|-------|--------|-------|--------|--------|--------|
| | | , 3/ | , 2/ | , 1/ | , 0/ | / | 0/ |
| 2/ | (| 83-/- | 053-5 | 150-2 | 284-0 | 467-0 | 71/-5 |
| | (| 65-8 | 72-1 | 8/-7 | 87-4 | 0/4-0 | 0/8-2 |
| | (| 026-1 | 035-1 | 046-3 | 058-/- | 068-1 | 074-7 |
| | B | 0-111 | 0-866 | 1-766 | 3-/-/8 | 4-4/0 | 6-4/8 |
| 3/ | (| 68-4 | 030-/- | 116-6 | 24/-3 | 405-4 | 627-8 |
| | (| 81-4 | 88-5 | 0/7-2 | 006-3 | 014-6 | 020-7 |
| | (| 048-7 | 06/-6 | 073-2 | 087-8 | 101-2 | 111-4 |
| | B | /-748 | 0-305 | 1-0/1 | 1-873 | 3-00/ | 4-5/3 |
| 4/ | (| 52-3 | 001-/- | 077-2 | 184-8 | 334-4 | 537-2 |
| | (| 00/-0 | 007-5 | 018-0 | 03/-1 | 04/-6 | 048-3 |
| | (| 076-0 | 1// -7 | 106-8 | 125-3 | 143-/- | 157-7 |
| | B | /-465 | /-833 | 0-348 | 1-000 | 1-846 | 3-/-57 |
| 5/ | (| ,, | ,, | ,, | 123-/- | 254-/- | 433-8 |
| | (| ,, | ,, | ,, | 055-5 | 068-8 | 080-7 |
| | (| ,, | ,, | ,, | 170-/- | 2/2-7 | 213-2 |
| | B | ,, | ,, | ,, | 0-3/4 | 1-/-17 | 1-730 |

| B1, 51/A, 11 | | | | | | | |
|--------------|---|-------|-------|--------|--------|--------|--------|
| | | , 3/ | , 2/ | , 1/ | , 0/ | / | 0/ |
| 2/ | (| 86-5 | 06/-7 | 160-3 | 30/-2 | 5// -3 | 741-0 |
| | (| 7/-4 | 76-0 | 84-/- | 0/2-0 | 0/8-8 | 003-2 |
| | (| 033-8 | 043-0 | 054-5 | 066-5 | 077-0 | 083-8 |
| | B | 0-102 | 0-851 | 1-745 | 2-870 | 4-351 | 6-344 |
| 3/ | (| 71-4 | 035-2 | 125-3 | 252-8 | 425-3 | 656-2 |
| | (| 85-6 | 0/3-1 | 002-2 | 011-7 | 020-4 | 026-8 |
| | (| 057-0 | 068-2 | 082-3 | 1/7-4 | 111-3 | 121-8 |
| | B | /-742 | 0-3/3 | 1-/-75 | 1-851 | 3-/-7/ | 4-453 |
| 4/ | (| 54-6 | 005-2 | 084-3 | 2/6-0 | 351-5 | 562-2 |
| | (| 004-1 | 013-0 | 024-/- | 035-5 | 046-5 | 055-6 |
| | (| 085-2 | 10/-4 | 117-1 | 136-2 | 154-6 | 170-0 |
| | B | /-460 | /-826 | 0-337 | 1-/-84 | 1-824 | 3-/-27 |
| 5/ | (| ,, | ,, | ,, | 131-7 | 267-8 | 454-7 |
| | (| ,, | ,, | ,, | 063-1 | 077-1 | 1// -5 |
| | (| ,, | ,, | ,, | 182-7 | 206-5 | 227-8 |
| | B | ,, | ,, | ,, | 0-283 | 1-/-02 | 1-71/ |

| B1, 60/A, 11 | | | | | | | |
|--------------|---|-------|-------|-------|-------|-------|-------|
| | | , 3/ | , 2/ | , 1/ | , 0/ | / | 0/ |
| 2/ | (| 005-3 | 088-1 | 205-0 | 366-8 | 588-1 | 881-3 |
| | (| 80-6 | 88-2 | 0/7-3 | 006-4 | 014-3 | 02/-2 |
| | (| 058-/ | 067-8 | 080-0 | 1/2-7 | 104-/ | 111-1 |
| | B | 0-158 | 1-//6 | 1-806 | 3-/55 | 4-467 | 6-503 |
| 3/ | (| 85-2 | 06/-7 | 164-5 | 312-7 | 513-6 | 782-5 |
| | (| 00/-2 | 007-7 | 018-1 | 03/-0 | 038-8 | 046-1 |
| | (| 082-7 | 1/4-5 | 11/-5 | 125-6 | 140-7 | 152-2 |
| | B | /-762 | 0-327 | 1-022 | 2-/14 | 3-056 | 4-572 |
| 4/ | (| 65-7 | 024-6 | 117-0 | 247-0 | 428-/ | 673-0 |
| | (| 020-2 | 030-4 | 042-8 | 056-1 | 068-6 | 08/-0 |
| | (| 112-6 | 127-8 | 147-0 | 168-0 | 188-7 | 206-3 |
| | B | /-474 | /-848 | 0-371 | 1-031 | 1-888 | 3-014 |
| 5/ | (| ,, | ,, | ,, | 172-3 | 330-6 | 548-2 |
| | (| ,, | ,, | ,, | 087-6 | 103-5 | 117-7 |
| | (| ,, | ,, | ,, | 221-/ | 25/-/ | 274-0 |
| | B | ,, | ,, | ,, | 0-316 | 1-/47 | 1-771 |

| B1, 68/A, 11 | | | | | | | |
|--------------|---|-------|-------|-------|-------|-------|--------|
| | | , 3/ | , 2/ | , 1/ | , 0/ | / | 0/ |
| 2/ | (| 014-2 | 103-3 | 23/-1 | 403-2 | 641-5 | 0/57-0 |
| | (| 87-8 | 0/6-/ | 005-7 | 015-7 | 024-1 | 03/-5 |
| | (| 071-/ | 081-6 | 1/4-8 | 108-5 | 120-6 | 128-4 |
| | B | 0-155 | 1-//1 | 1-800 | 3-/47 | 4-456 | 6-488 |
| 3/ | (| 0/2-5 | 072-7 | 185-5 | 345-0 | 561-3 | 850-7 |
| | (| 008-/ | 017-0 | 028-3 | 040-0 | 050-6 | 058-5 |
| | (| 1/7-6 | 110-5 | 126-6 | 144-1 | 160-3 | 172-7 |
| | B | /-760 | 0-324 | 1-017 | 2-/08 | 3-048 | 4-561 |
| 4/ | (| 71-5 | 035-/ | 134-4 | 274-2 | 47/-0 | 733-/ |
| | (| 030-5 | 041-5 | 055-/ | 07/-2 | 082-7 | 1/4-/ |
| | (| 130-0 | 146-4 | 167-1 | 2/0-/ | 212-2 | 231-2 |
| | B | /-473 | /-846 | 0-368 | 1-027 | 1-882 | 3-005 |
| 5/ | (| ,, | ,, | ,, | 2/4-/ | 364-3 | 6/8-5 |
| | (| ,, | ,, | ,, | 103-1 | 120-3 | 135-6 |
| | (| ,, | ,, | ,, | 247-0 | 277-2 | 304-3 |
| | B | ,, | ,, | ,, | 0-313 | 1-/43 | 1-765 |

| B1, 72/A, 11 | | | | | | | |
|--------------|---|-------|-------|-------|-------|-------|--------|
| | | , 3/ | , 2/ | , 1/ | , 0/ | / | 0/ |
| 2/ | (| 025-2 | 122-2 | 26/-2 | 448-7 | 708-0 | 0051-5 |
| | (| 0/7-0 | 005-8 | 016-5 | 027-3 | 036-5 | 042-4 |

| B1, 0/1/A, 11 | | | | | | | |
|---------------|---|--------|--------|--------|---------|--------|---------|
| | | , 3/ | , 2/ | , 1/ | , 0/ | / | 0/ |
| 2/ | (| 062-3 | 185-7 | 360-0 | 601-1 | 0/31-0 | 0368-/- |
| | (| 026-/- | 037-1 | 050-7 | 064-4 | 076-1 | 083-5 |
| | (| 148-8 | 164-3 | 183-6 | 203-7 | 221-2 | 232-5 |
| | B | 0-155 | 1-/-/1 | 1-800 | 3-/-/47 | 4-456 | 6-488 |
| 3/ | (| 032-3 | 143-4 | 30/-6 | 520-5 | 820-/- | 0220-7 |
| | (| 053-6 | 066-3 | 082-/- | 1/8-1 | 112-8 | 123-7 |
| | (| 187-8 | 206-5 | 230-0 | 255-0 | 278-1 | 3/5-5 |
| | B | /-760 | 0-323 | 1-017 | 2-/-08 | 3-048 | 4-561 |
| 4/ | (| 003-3 | 1/1-1 | 228-8 | 422-5 | 7/2-2 | 0057-5 |
| | (| 085-0 | 100-2 | 118-8 | 138-5 | 157-3 | 172-8 |
| | (| 234-8 | 258-4 | 287-6 | 32/-2 | 35/-5 | 374-7 |
| | B | /-473 | /-846 | 0-368 | 1-027 | 1-882 | 3-005 |
| 5/ | (| ,, | ,, | ,, | 311-2 | 547-2 | 871-5 |
| | (| ,, | ,, | ,, | 185-6 | 21/-4 | 230-5 |
| | (| ,, | ,, | ,, | 4/5-6 | 435-/- | 470-0 |
| | B | ,, | ,, | ,, | 0-313 | 1-/-43 | 1-765 |

| B1, 002/A, 11 | | | | | | | |
|---------------|---|-------|---------|--------|--------|--------|--------|
| | | , 3/ | , 2/ | , 1/ | , 0/ | / | 0/ |
| 2/ | (| 087-7 | 228-3 | 426-7 | 702-/- | 0078-5 | 0577-4 |
| | (| 041-3 | 053-8 | 07/-/- | 084-1 | 1/7-1 | 105-4 |
| | (| 170-1 | 188-0 | 210-3 | 233-4 | 253-5 | 266-4 |
| | B | 0-2/4 | 1-/-/47 | 1-877 | 3-054 | 4-603 | 6-7// |
| 3/ | (| 053-1 | 180-3 | 358-3 | 610-/- | 0/51-7 | 041/-3 |
| | (| 072-1 | 086-2 | 103-5 | 121-5 | 138-/- | 150-1 |
| | (| 215-2 | 236-7 | 263-5 | 3/2-0 | 318-1 | 337-8 |
| | B | /-785 | 0-366 | 1-076 | 2-/-88 | 3-158 | 4-710 |
| 4/ | (| 020-1 | 120-3 | 278-/- | 5/8-8 | 806-4 | 0223-0 |
| | (| 107-0 | 124-/- | 144-6 | 166-5 | 187-4 | 204-7 |
| | (| 27/-0 | 3/5-8 | 33/-/- | 364-5 | 4/8-6 | 427-0 |
| | B | /-5/0 | /-874 | 0-411 | 1-086 | 2-/-63 | 3-114 |
| 5/ | (| ,, | ,, | ,, | 372-3 | 641-4 | 0011-2 |
| | (| ,, | ,, | ,, | 218-8 | 245-3 | 27/-/- |
| | (| ,, | ,, | ,, | 450-5 | 5/4-8 | 534-7 |
| | B | ,, | ,, | ,, | 0-354 | 1-000 | 1-843 |

| B1, 016/A, 11 | | | | | | | |
|---------------|---|-------|--------|--------|-------|--------|--------|
| | | , 3/ | , 2/ | , 1/ | , 0/ | / | 0/ |
| 2/ | (| 112-0 | 27/-7 | 5/2-2 | 801-0 | 0223-5 | 0783-2 |
| | (| 06/-1 | 073-1 | 1/0-/- | 107-0 | 121-5 | 130-7 |
| | (| 203-3 | 222-8 | 247-0 | 272-1 | 3/3-7 | 307-7 |
| | B | 0-200 | 1-/-57 | 2-//0 | 3-071 | 4-627 | 6-722 |
| 3/ | (| 073-2 | 216-/- | 415-6 | 7/7-8 | 0081-3 | 06/4-6 |
| | (| 1/3-6 | 11/-3 | 128-7 | 148-8 | 167-0 | 180-7 |
| | (| 252-3 | 275-5 | 304-5 | 335-2 | 363-1 | 384-1 |
| | B | /-8// | 0-373 | 1-086 | 2-001 | 3-176 | 4-735 |
| 4/ | (| 036-1 | 148-6 | 325-5 | 573-2 | 0/18-4 | 0385-6 |
| | (| 132-6 | 151-5 | 174-5 | 20/-1 | 222-3 | 241-6 |
| | (| 310-5 | 34/-2 | 374-7 | 412-6 | 448-7 | 478-7 |
| | B | /-5/3 | /-878 | 0-418 | 1-1/5 | 2-/-76 | 3-132 |
| 5/ | (| ,, | ,, | ,, | 431-5 | 733-2 | 0148-2 |
| | (| ,, | ,, | ,, | 257-5 | 287-1 | 313-4 |
| | (| ,, | ,, | ,, | 503-6 | 550-7 | 6/3-5 |
| | B | ,, | ,, | ,, | 0-361 | 1-01/ | 1-856 |

| B1, 042/A, 11 | | | | | | | |
|---------------|---|--------|--------|--------|--------|---------|---------|
| | | , 3/ | , 2/ | , 1/ | , 0/ | / | 0/ |
| 2/ | (| 148-/- | 330-7 | 588-6 | 0/46-8 | 0437-/- | 1086-0 |
| | (| 085-4 | 101-5 | 121-0 | 140-6 | 157-4 | 168-1 |
| | (| 250-4 | 273-0 | 301-1 | 330-1 | 355-2 | 371-4 |
| | B | 0-207 | 1-/-67 | 2-/-04 | 3-1/1 | 4-655 | 6-76/ |
| 3/ | (| 102-7 | 268-4 | 500-/- | 827-1 | 0272-/- | 0867-2 |
| | (| 125-2 | 143-4 | 165-7 | 2//--/ | 210-0 | 225-7 |
| | (| 307-2 | 334-2 | 367-7 | 403-2 | 435-5 | 46/-8 |
| | B | /-8/4 | 0-380 | 1-1/7 | 2-016 | 3-2/6 | 4-763 |
| 4/ | (| 06/-8 | 2/0-2 | 4/5-6 | 682-8 | 0083-0 | 0625-/- |
| | (| 170-2 | 2/2-0 | 218-6 | 247-/- | 273-8 | 3/6-1 |
| | (| 374-6 | 408-/- | 45/-/- | 5/2-6 | 534-3 | 57/-1 |
| | B | /-5/7 | /-883 | 0-426 | 1-106 | 2-0/1 | 3-152 |
| 5/ | (| ,, | ,, | ,, | 518-5 | 868-4 | 035/-6 |
| | (| ,, | ,, | ,, | 314-4 | 348-6 | 38/-/- |
| | (| ,, | ,, | ,, | 6/8-/- | 652-5 | 702-3 |
| | B | ,, | ,, | ,, | 0-37/ | 1-020 | 1-870 |

B1, 0//A 03/A

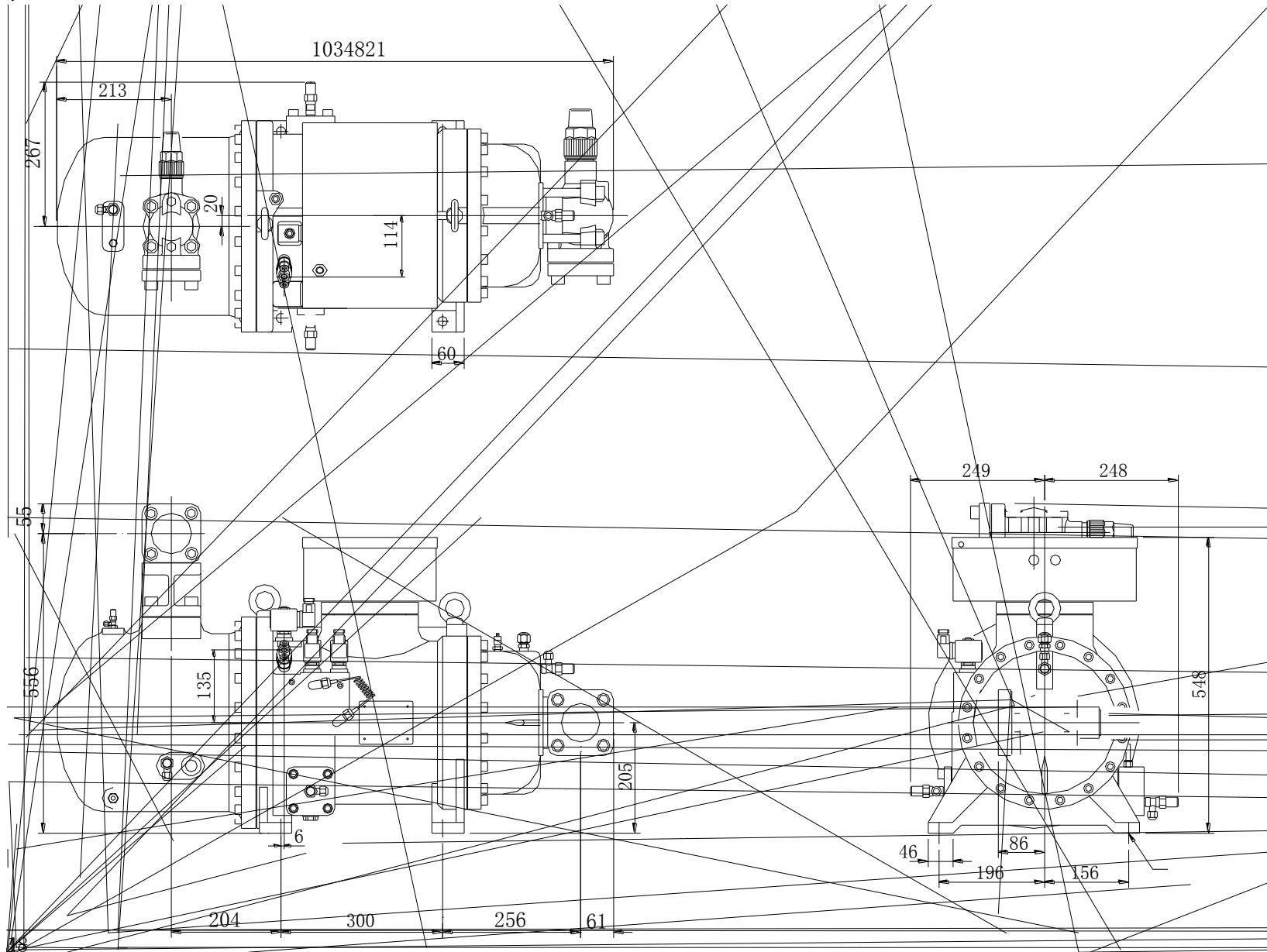

B1, 07/A

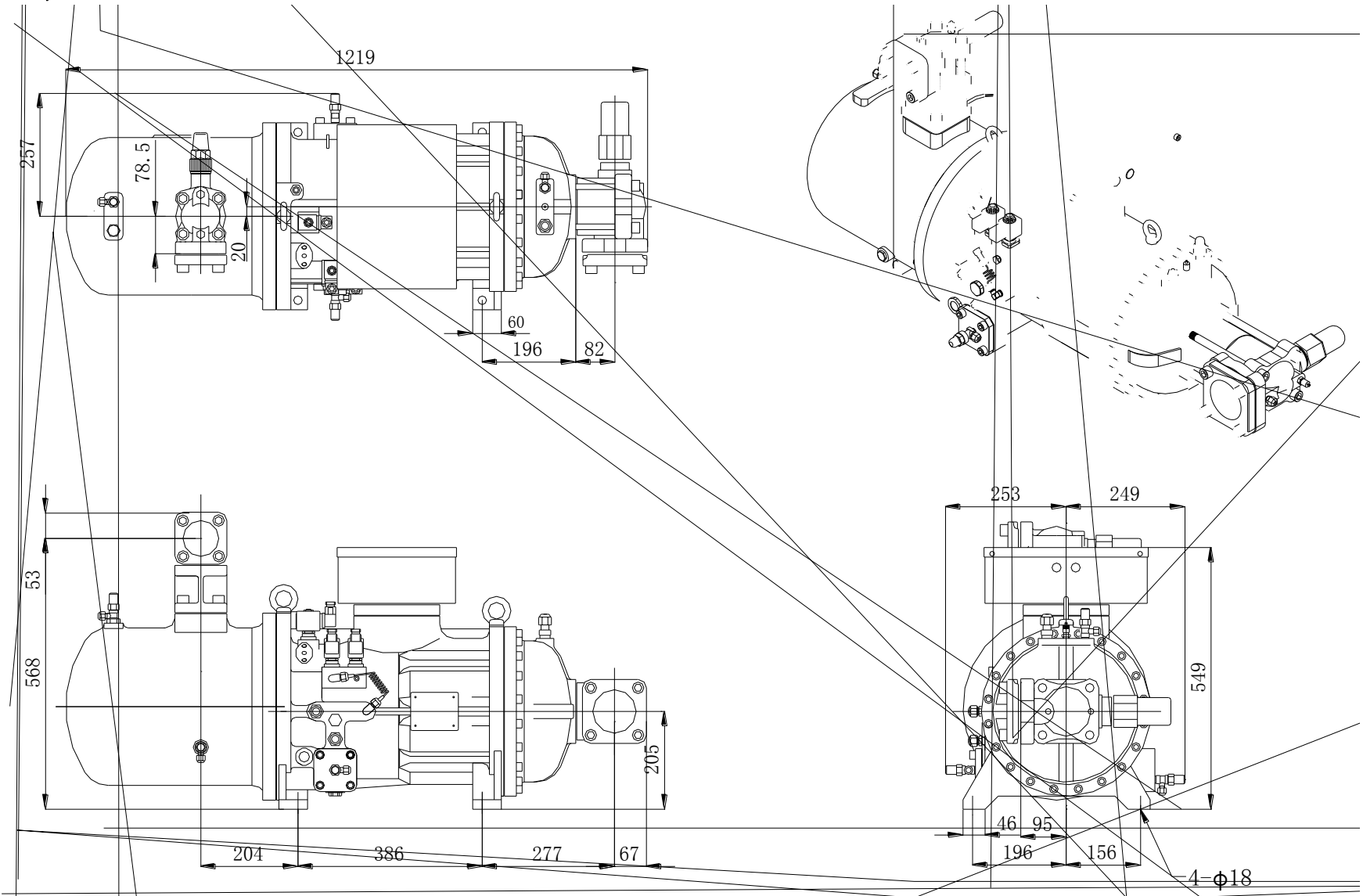

B1,1//A 51/A 51/

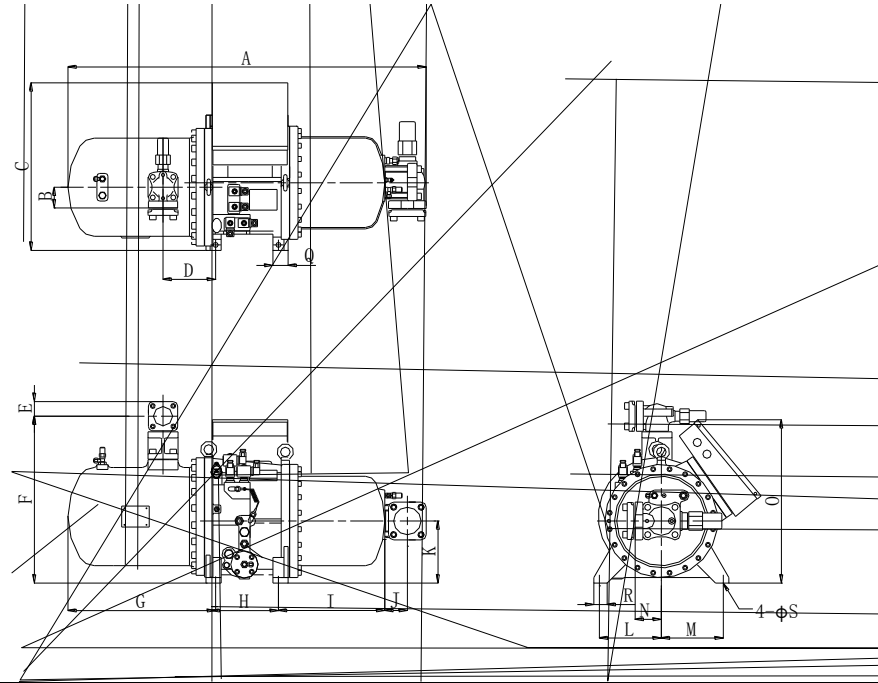

| | | B1,1//A 51/A 51/ | | | | | | | | | | | | | | | | | |
|--------------|------|------------------|-----|-----|----|-----|-----|-----|-----|-----|-----|-----|-----|-----|-----|-----|----|-----|----|
| | | A | B | C | D | E | F | G | H | I | J | K | L | | | | | | |
| B1,1//A | 02// | 68 | 51/ | 080 | 44 | 5/2 | 425 | 117 | 275 | 71 | 114 | 114 | 114 | 84 | 481 | 275 | 44 | 37 | 07 |
| B1,12/A%15/A | 0288 | 75 | 571 | 1/1 | 50 | 563 | 456 | 140 | 288 | 86 | 146 | 13/ | 13/ | 0/6 | 511 | 275 | 44 | 37 | 07 |
| B1,2//A | 0410 | 75 | 571 | 1/1 | 50 | 563 | 50/ | 174 | 333 | 86 | 146 | 13/ | 13/ | 0/6 | 511 | 275 | 44 | 37 | 07 |
| B1,20/A | 0373 | 75 | 571 | 1/1 | 50 | 563 | 50/ | 140 | 333 | 86 | 146 | 13/ | 13/ | 0/6 | 511 | 275 | 44 | 37 | 07 |
| B1,23/A%26/A | 0484 | 85 | 571 | 1/1 | 56 | 6/3 | 50/ | 174 | 381 | 0/2 | 146 | 13/ | 13/ | 021 | 511 | 275 | 44 | 37 | 07 |
| B1,30/A | 043/ | 85 | 644 | 110 | 56 | 644 | 502 | 177 | 322 | 0/2 | 165 | 16/ | 12/ | 021 | 541 | 3/7 | 6/ | 0// | 11 |
| B1,36/A | 0555 | 85 | 644 | 110 | 56 | 644 | 550 | 21/ | 367 | 0/2 | 165 | 16/ | 12/ | 021 | 541 | 3/7 | 6/ | 0// | 11 |
| B1,40/A | 0564 | 0/6 | 687 | 120 | 65 | 678 | 585 | 177 | 373 | 0/2 | 165 | 16/ | 12/ | 021 | 527 | 34/ | 6/ | 0// | 11 |
| B1,44/A | 0672 | 0/6 | 687 | 125 | 65 | 7// | 61/ | 21/ | 425 | 0/2 | 17/ | 16/ | 12/ | 021 | 531 | 34/ | 6/ | 0// | 11 |
| B1,47/A | 06/6 | 0/6 | 687 | 120 | 65 | 678 | 585 | 21/ | 373 | 0/2 | 165 | 16/ | 12/ | 021 | 527 | 34/ | 6/ | 0// | 11 |
| B1,51/A | 08/3 | 0/6 | 687 | 125 | 65 | 7// | 61/ | 21/ | 414 | 11/ | 17/ | 16/ | 12/ | 050 | 531 | 34/ | 6/ | 0// | 11 |

B1 , 51/A 82/A 51/

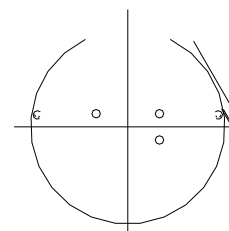
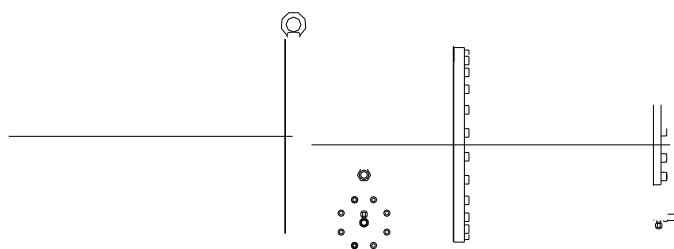
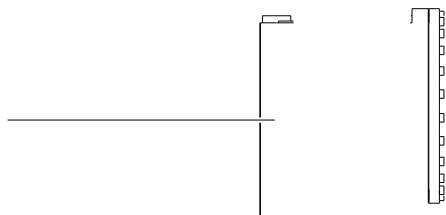

| | B1 , 51/A 82/A 51/ | | | | | | | | | | | | | | | | |
|----------------|--------------------|-----|-----|-----|-----|-----|-----|-----|-----|-----|-----|-----|-----|-----|-----|-----|----|
| | | A | B | C | D | E | F | G | H | I | J | K | L | | | | |
| B1 , 51/A | 0632 | 0/6 | 7// | 125 | 40/ | 050 | 7// | 65 | 61/ | 21/ | 512 | 627 | 16/ | 12/ | 531 | 34/ | 6/ |
| B1 , 60/A | 0843 | 02/ | 701 | 152 | 474 | 050 | 740 | 0/4 | 711 | 242 | 587 | 7/7 | 16/ | 12/ | 571 | 354 | 7/ |
| B1 , 68/A%72/A | 1/28 | 02/ | 701 | 152 | 474 | 050 | 740 | 0/4 | 711 | 307 | 587 | 7/7 | 16/ | 12/ | 571 | 354 | 7/ |
| B1 , 82/A | 1/62 | 05/ | 701 | 152 | 528 | 050 | 740 | 0/4 | 711 | 307 | 641 | 7/7 | 16/ | 12/ | 571 | 354 | 7/ |

B1 , 0/1/A 002/A

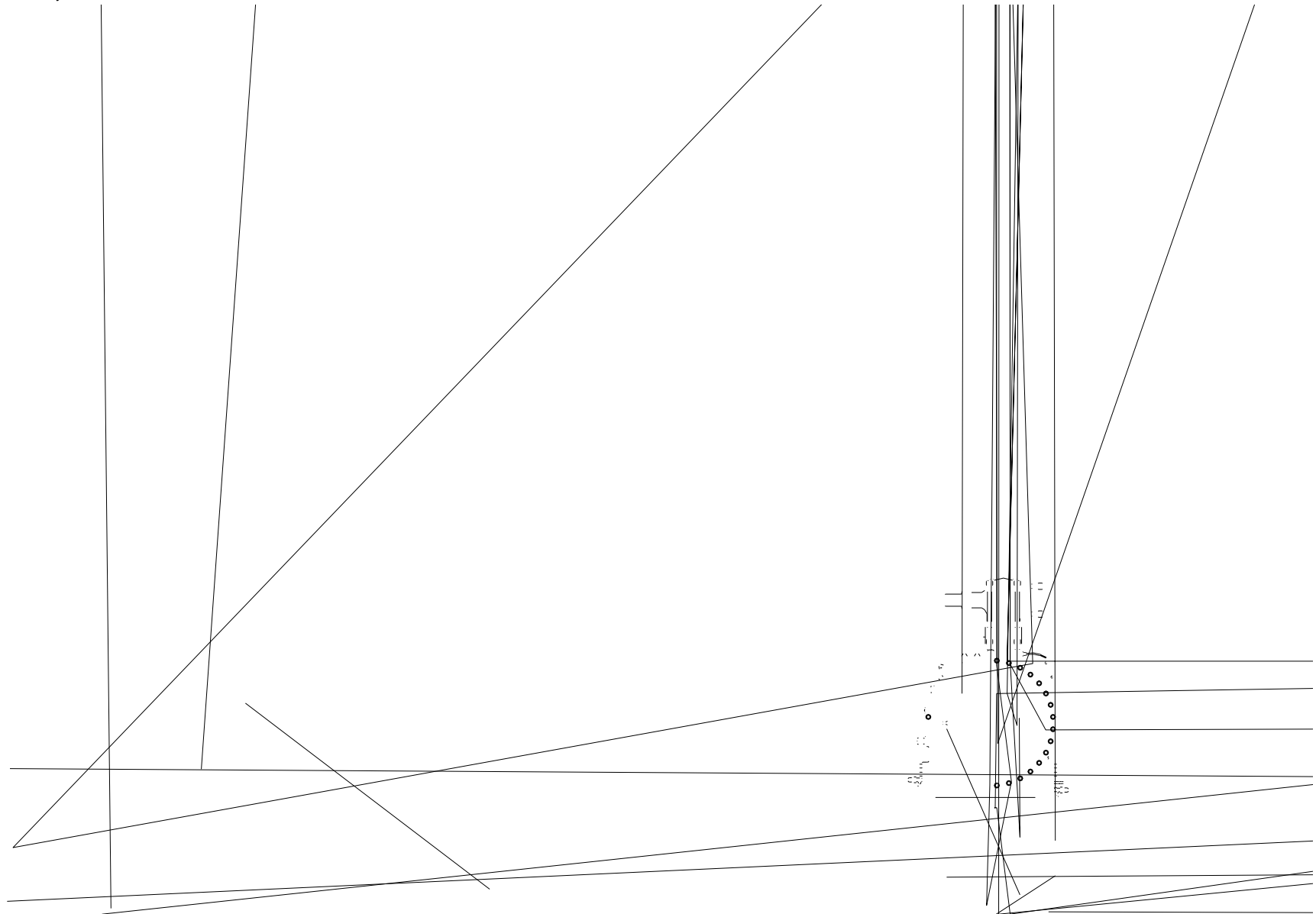

B1 , 016/A 042/A

B1, 0//A %03/A

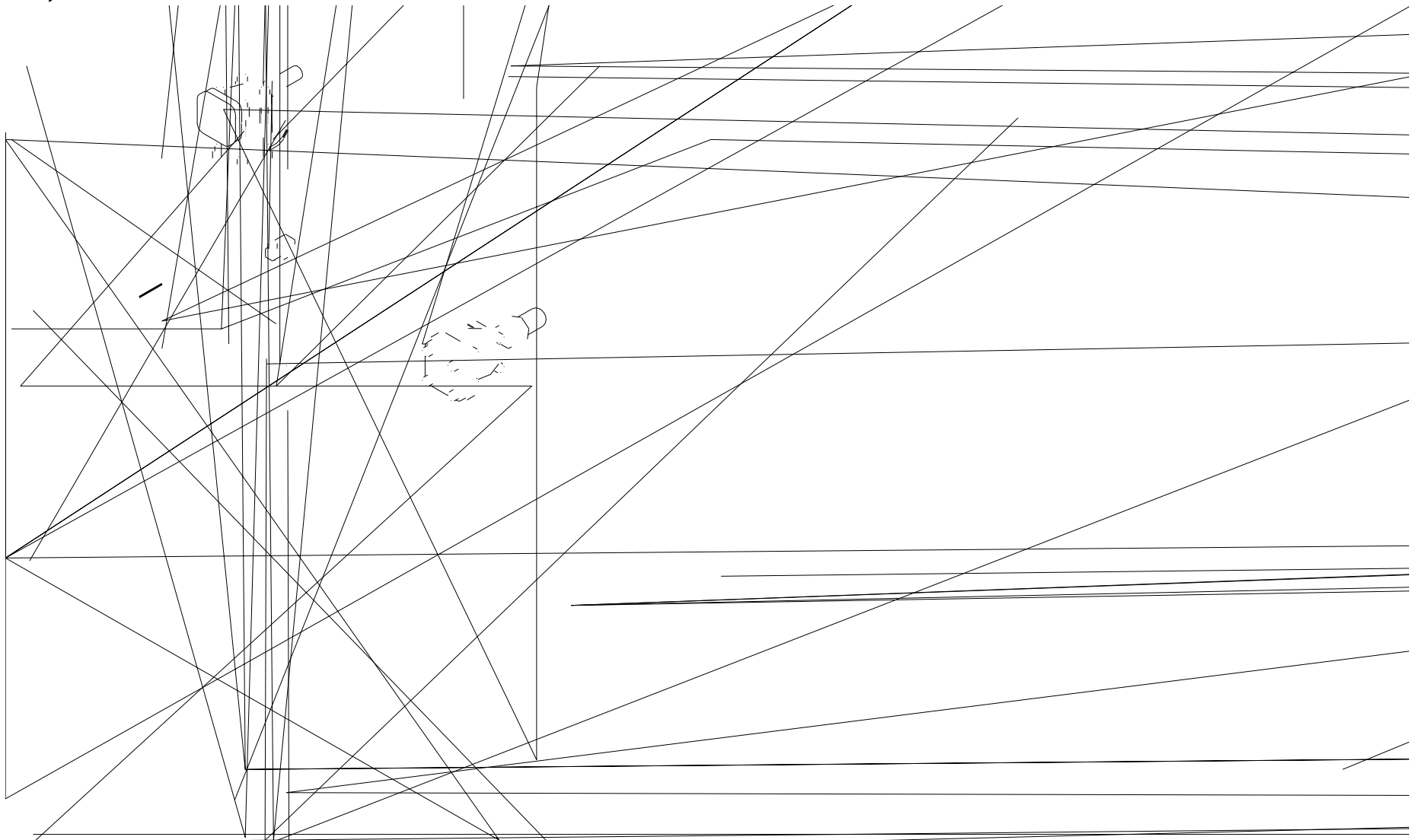

B, 07/A



B1,1//A 51/A 51/

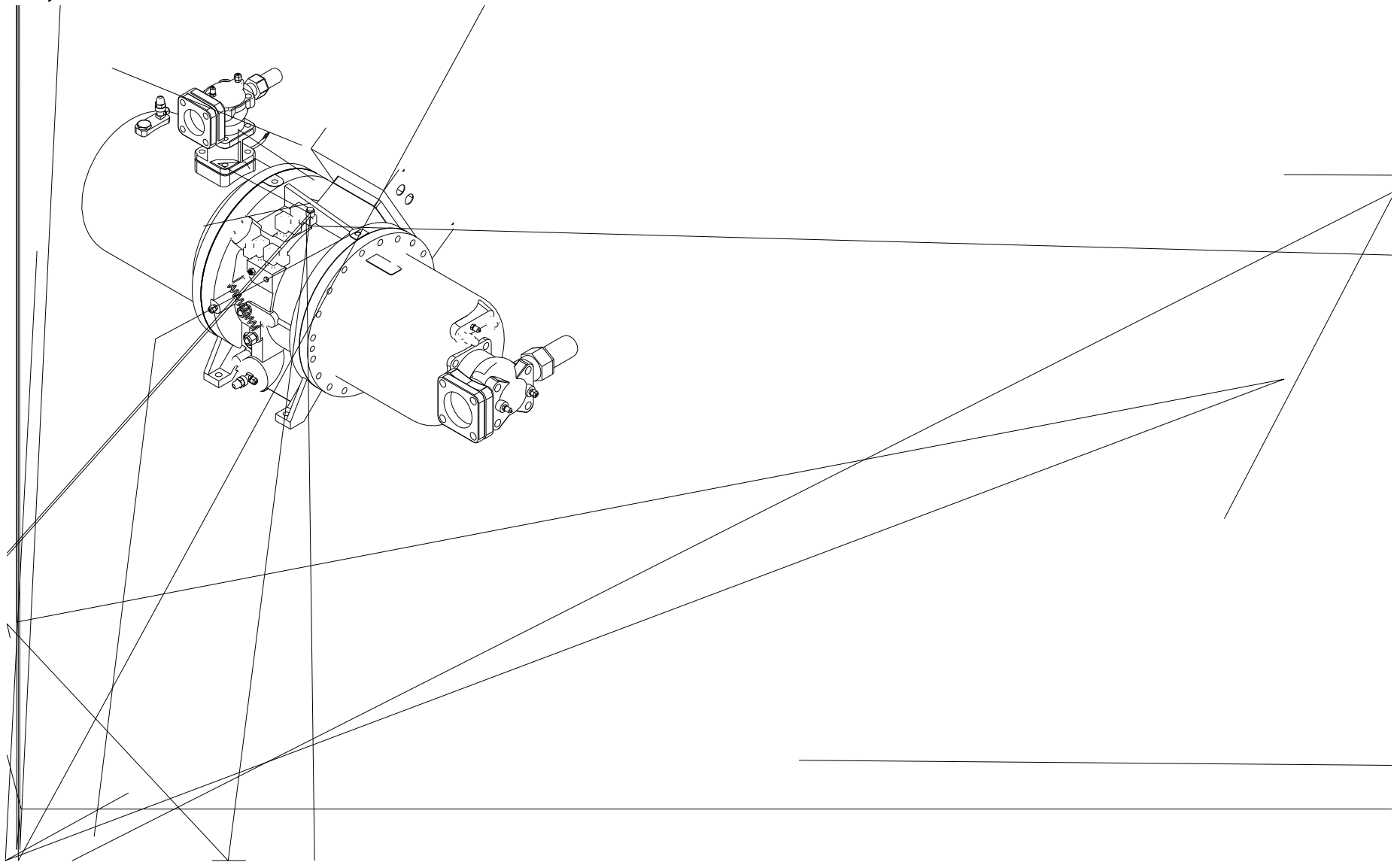

B1, 51/A 82/A 51/

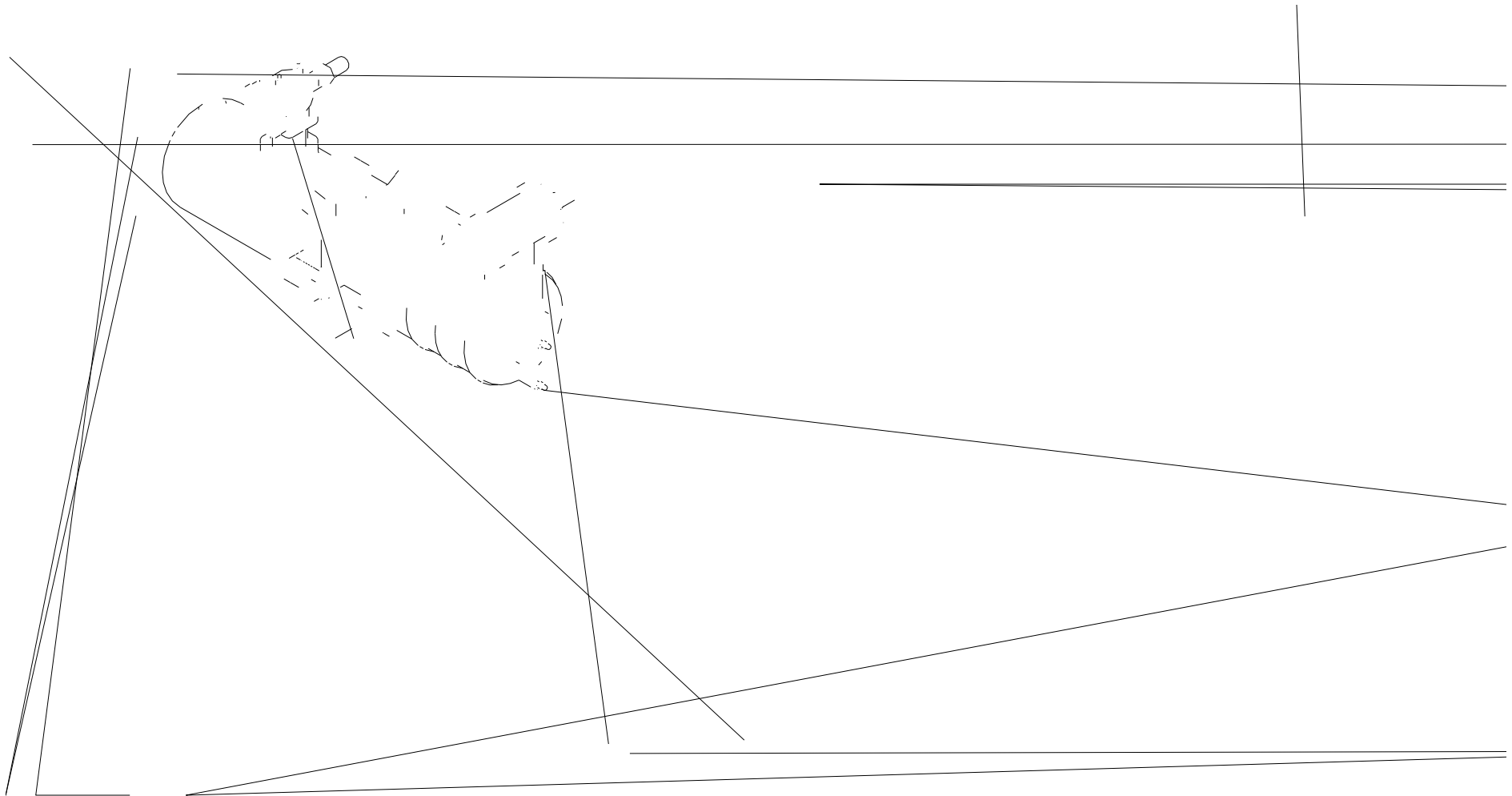

B1, 0/1/A %002/A

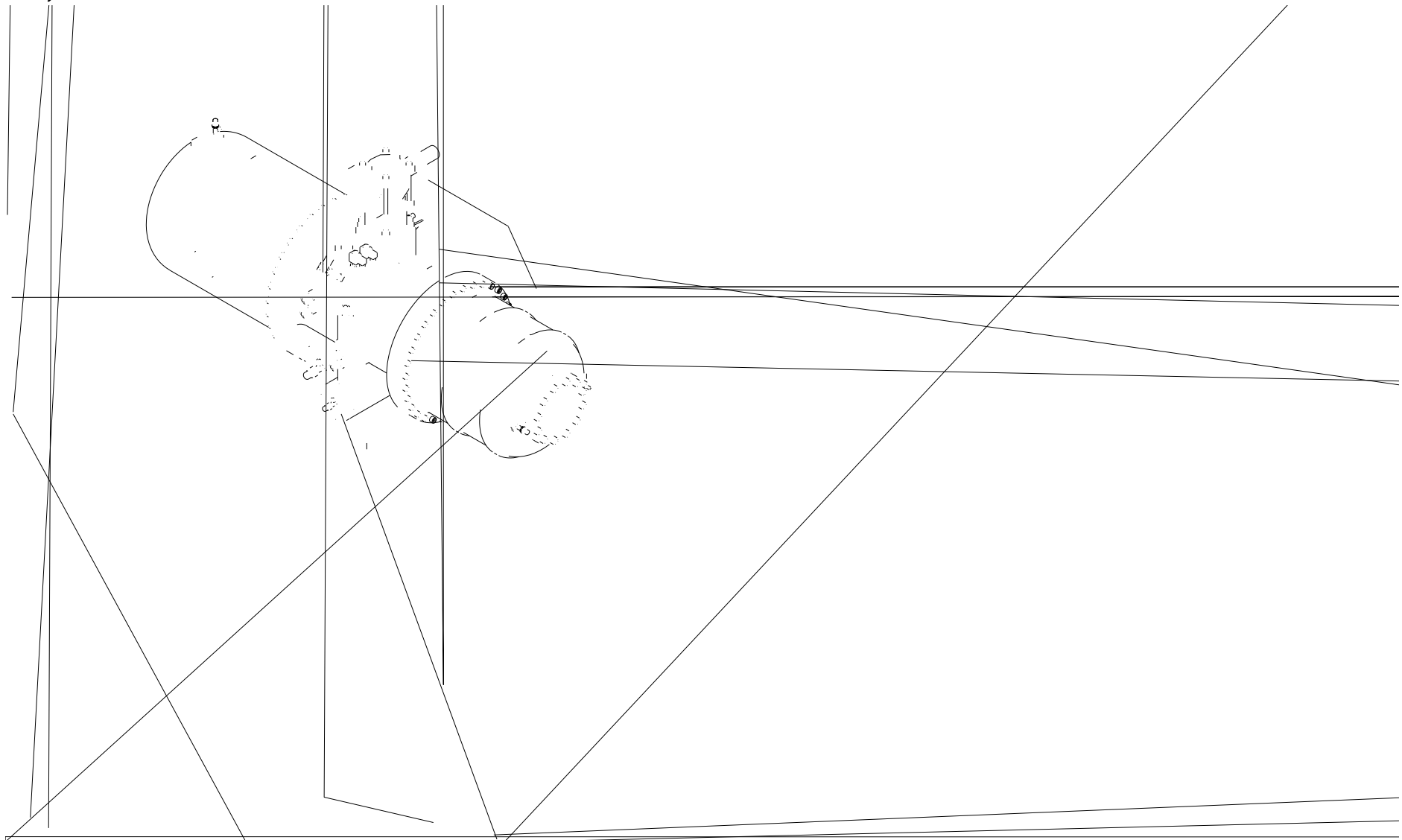

B1, 0//A 03/A

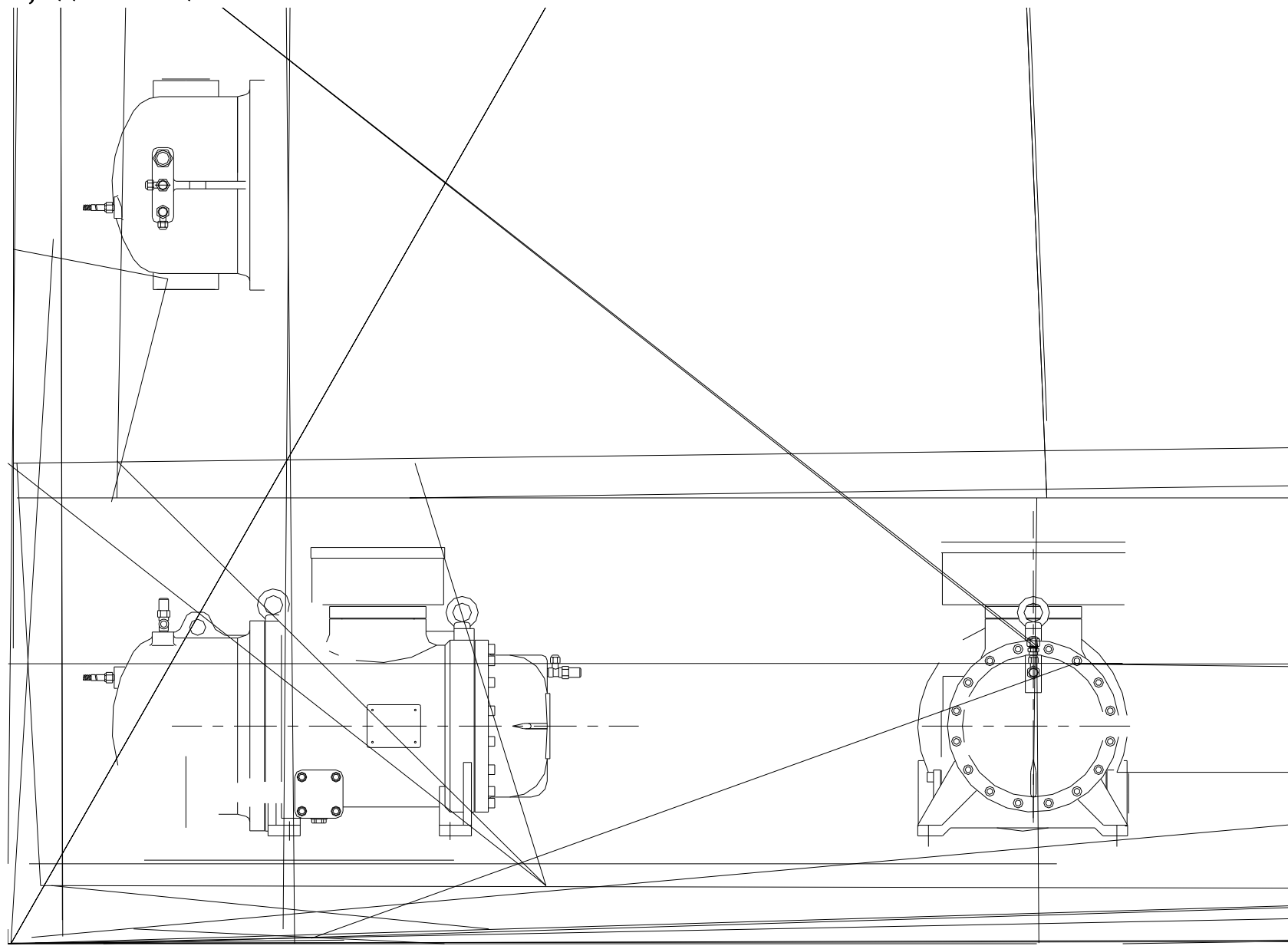

B1, 07/A

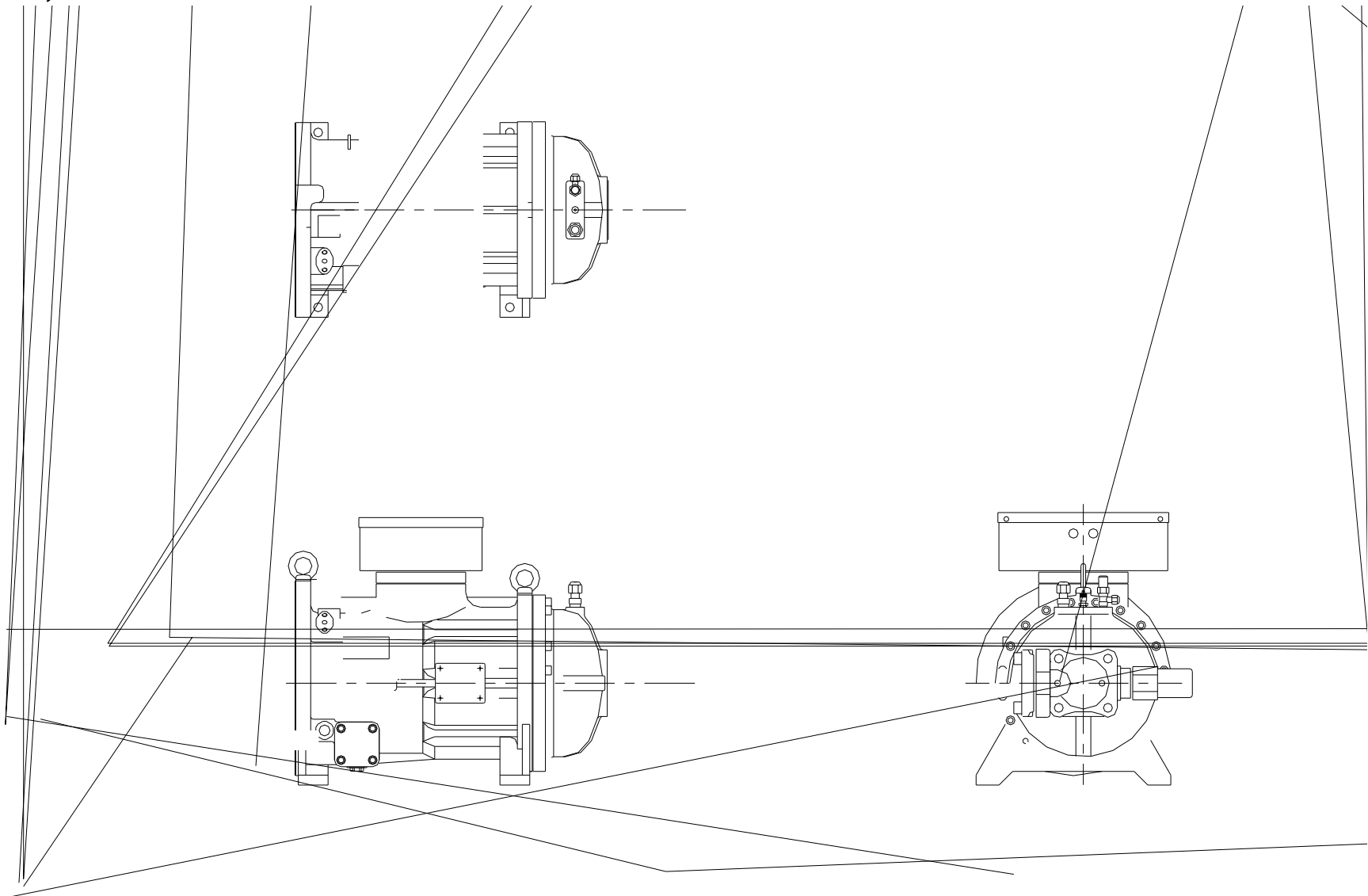

B1, 1//A 51/A 51/

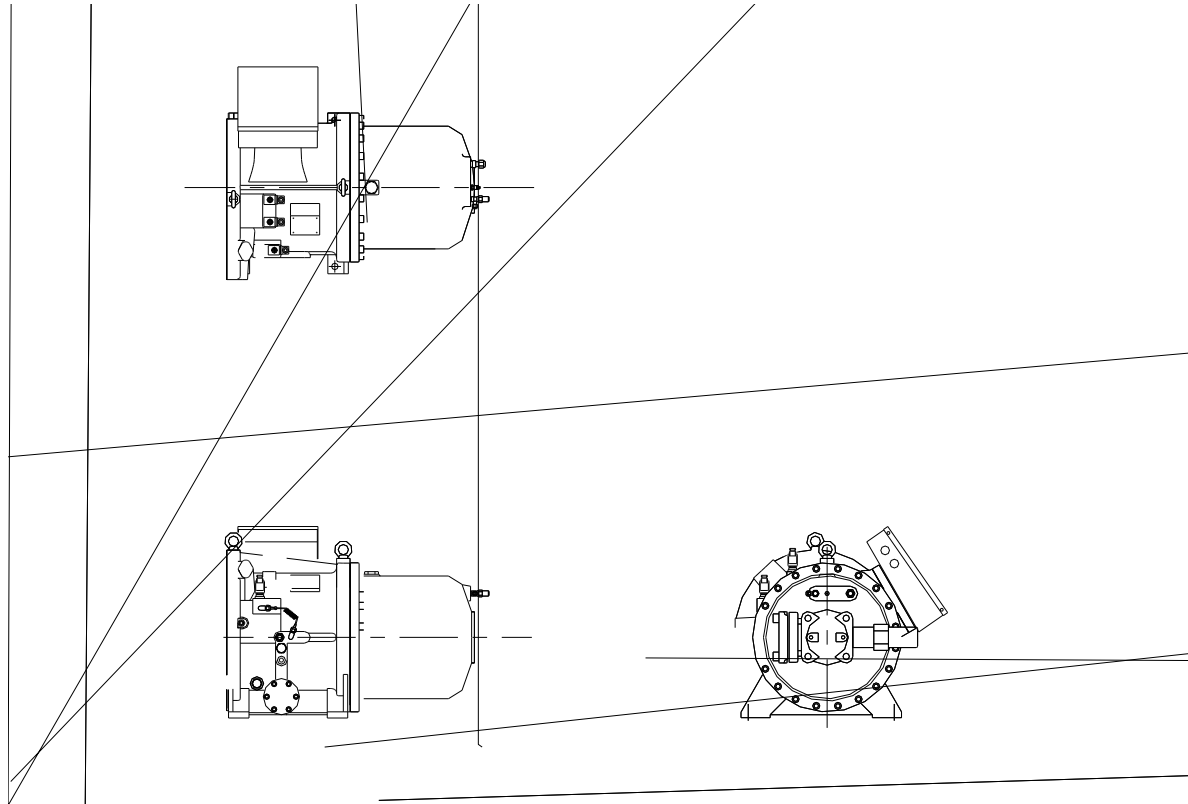

| | B1, 1//A 51/A 51/ (| | | | | | | | | | | | | | | | | | |
|---------------|---------------------|-----|-----|-----|-----|-----|-----|-----|-----|-----|-----|-----|-----|-----|-----|-----|----|-----|----|
| | A | B | C | D | E | F | G | H | I | J | K | L | | | | | | | |
| B1, 1//A | 0077 | 264 | 172 | 0/2 | 107 | 3/7 | 117 | 275 | 71 | 114 | 024 | 114 | 114 | 85 | 481 | 251 | 40 | 37 | 07 |
| B1, 12/. 15/A | 02// | 3// | 215 | 007 | 130 | 341 | 140 | 288 | 86 | 146 | 058 | 13/ | 13/ | 0/6 | 511 | 275 | 44 | 37 | 07 |
| B1, 2//A | 0268 | 3// | 215 | 007 | 130 | 341 | 174 | 333 | 86 | 146 | 058 | 13/ | 13/ | 0/6 | 511 | 275 | 44 | 37 | 07 |
| B1, 20/A | 0241 | 3// | 215 | 007 | 130 | 341 | 140 | 333 | 86 | 146 | 058 | 13/ | 13/ | 0/6 | 511 | 275 | 44 | 37 | 07 |
| B1, 23/. 26/A | 0341 | 3// | 215 | 007 | 130 | 341 | 174 | 381 | 0/2 | 146 | 058 | 13/ | 13/ | 021 | 511 | 275 | 44 | 37 | 07 |
| B1, 30/A | 0352 | 337 | 254 | 011 | 166 | 406 | 177 | 322 | 0/2 | 164 | 11/ | 16/ | 12/ | 021 | 541 | 3/7 | 6/ | 0// | 11 |
| B1, 36/A | 0430 | 337 | 254 | 011 | 166 | 406 | 21/ | 367 | 0/2 | 164 | 11/ | 16/ | 12/ | 021 | 541 | 3/7 | 6/ | 0// | 11 |
| B1, 40/A | 0404 | 38/ | 254 | 011 | 166 | 406 | 177 | 373 | 0/2 | 164 | 11/ | 16/ | 12/ | 021 | 527 | 34/ | 6/ | 0// | 11 |

B1 , 51/A 82/A 51/

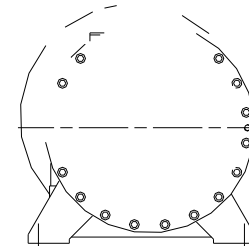
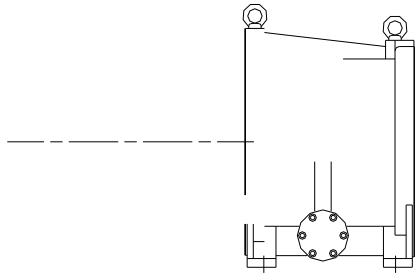
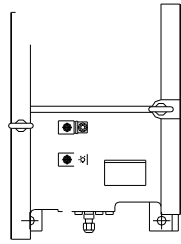

| | B1 , 51/ A 82/ A | | | | | | | | | | | | | | | | | |
|----------------|------------------|-----|-----|-----|-----|-----|-----|-----|-----|-----|-----|-----|-----|-----|-----|-----|-----|----|
| | | A | B | C | D | E | F | G | H | I | J | K | L | | | | | |
| B1 , 51/A | 0546 | 38/ | 268 | 40/ | 050 | 03/ | 220 | 504 | 21/ | 512 | 627 | 013 | 140 | 16/ | 12/ | 531 | 34/ | 6/ |
| B1 , 60/A | 0652 | 4/4 | 268 | 474 | 050 | 074 | 235 | 52/ | 242 | 587 | 7/7 | 013 | 14/ | 16/ | 12/ | 571 | 354 | 7/ |
| B1 , 68/. 72/A | 0764 | 4/8 | 268 | 474 | 050 | 074 | 235 | 52/ | 307 | 587 | 7/7 | 013 | 14/ | 16/ | 12/ | 571 | 354 | 7/ |
| B1 , 82/A | 08/5 | 4/8 | 268 | 528 | 050 | 074 | 235 | 52/ | 307 | 641 | 7/7 | 013 | 14/ | 16/ | 12/ | 571 | 354 | 7/ |

B1 , 0/1/A 002/A

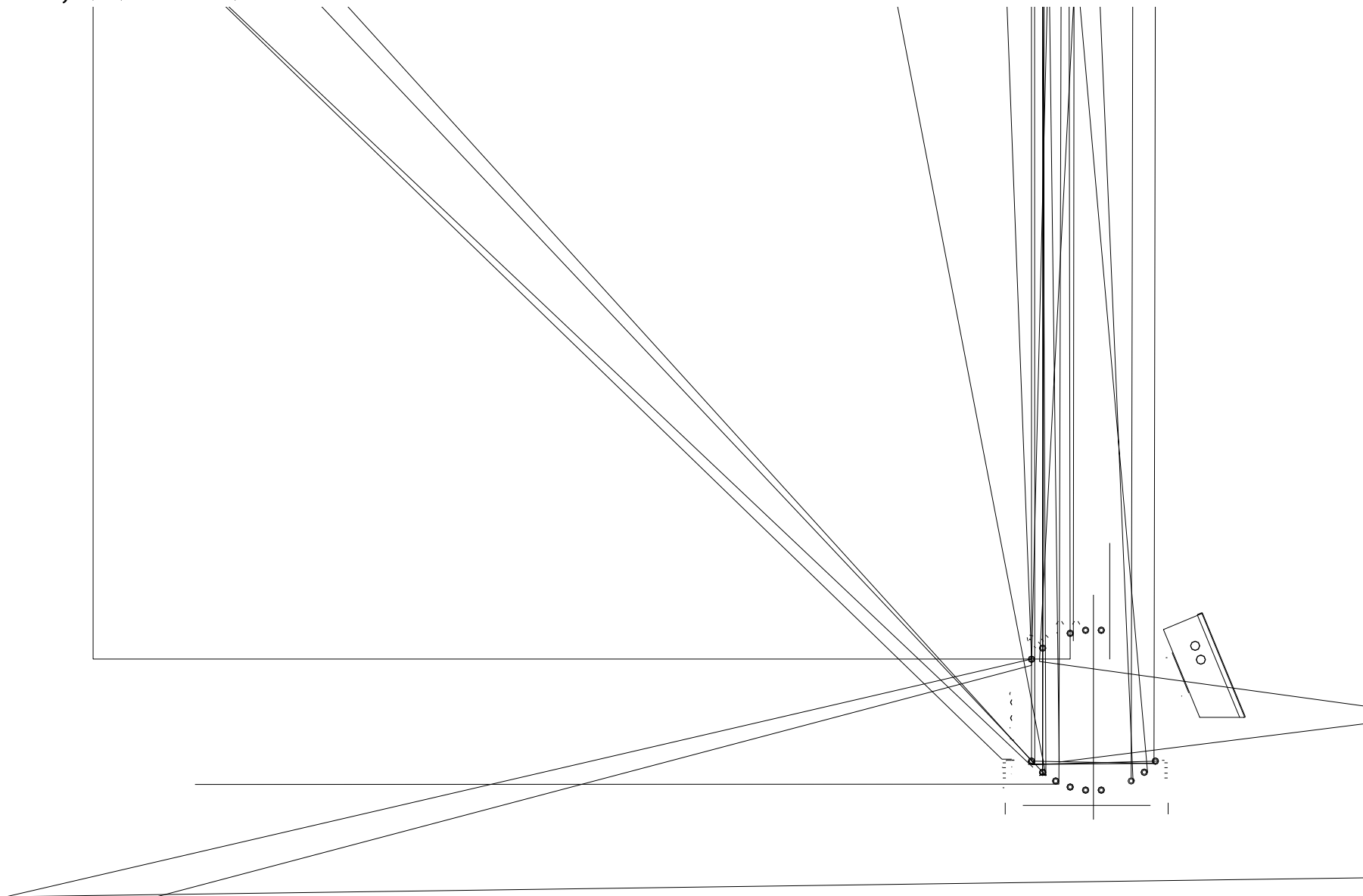

B1 , 016/A 042/A

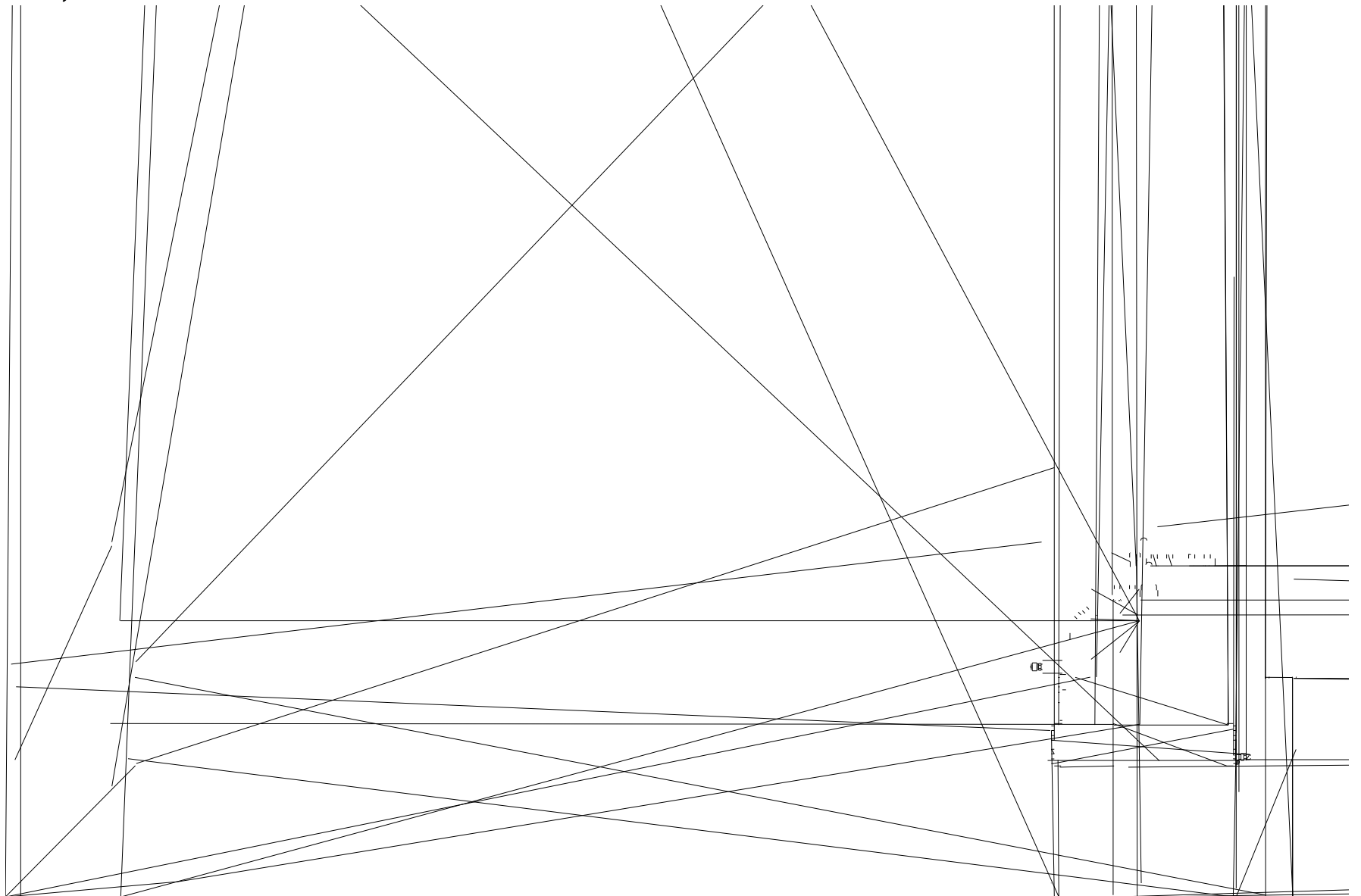

B1, 0//A %03/A

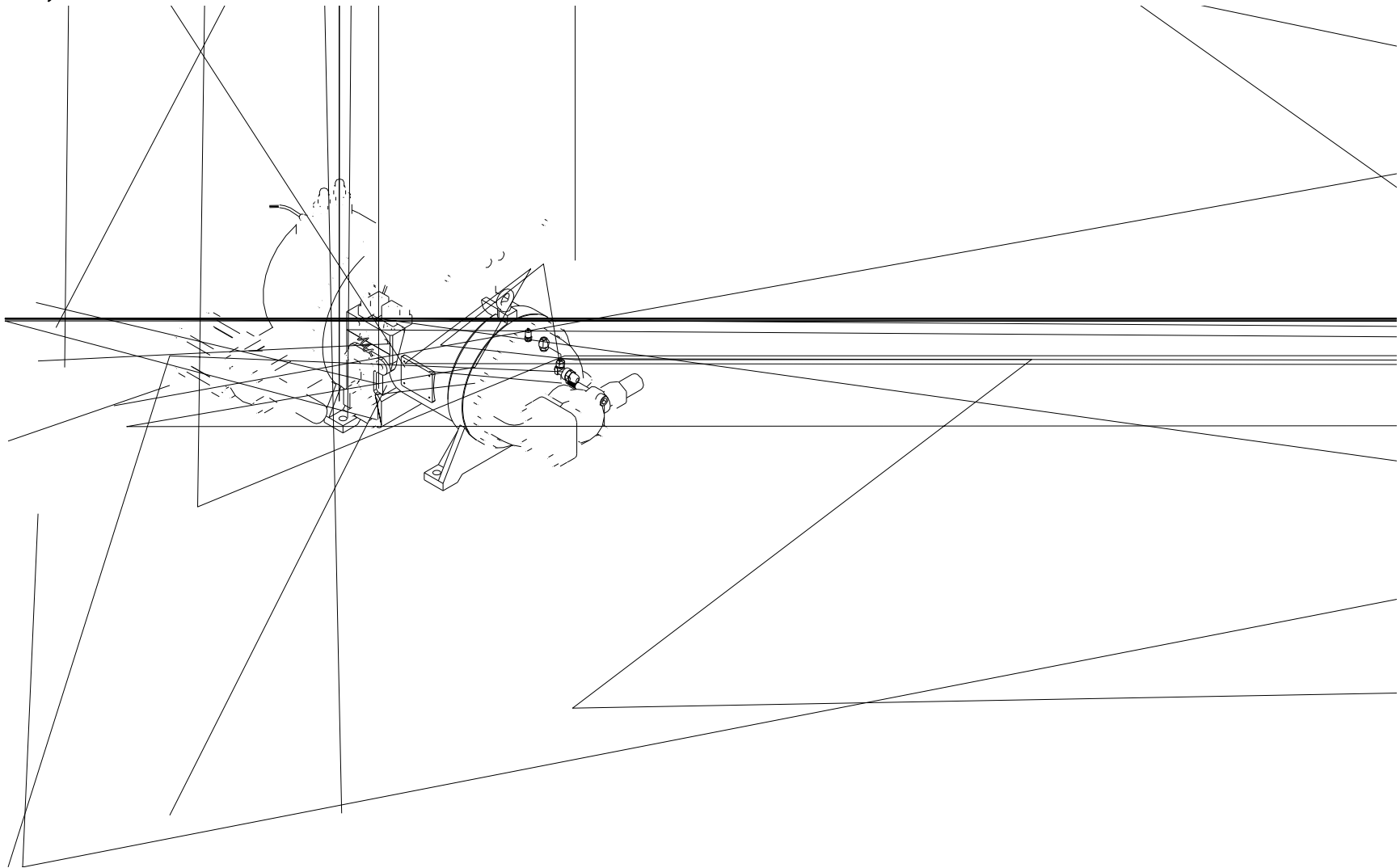

B1, 07/A

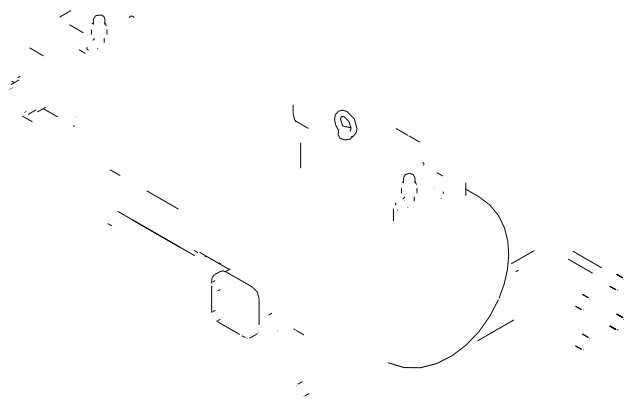

B1, 1//A 51/A 51/

1/4"

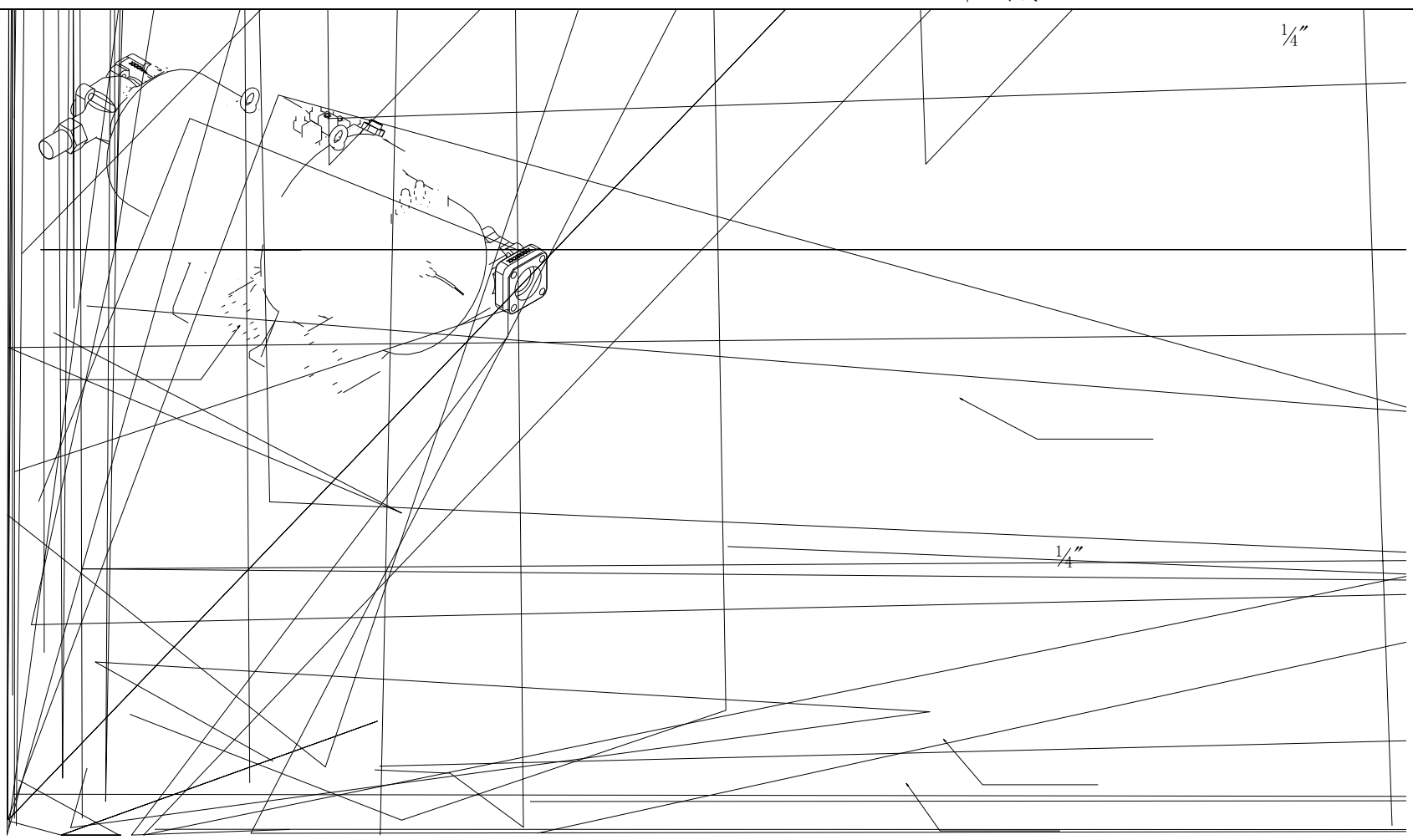

B1, 51/A 82/A 51/

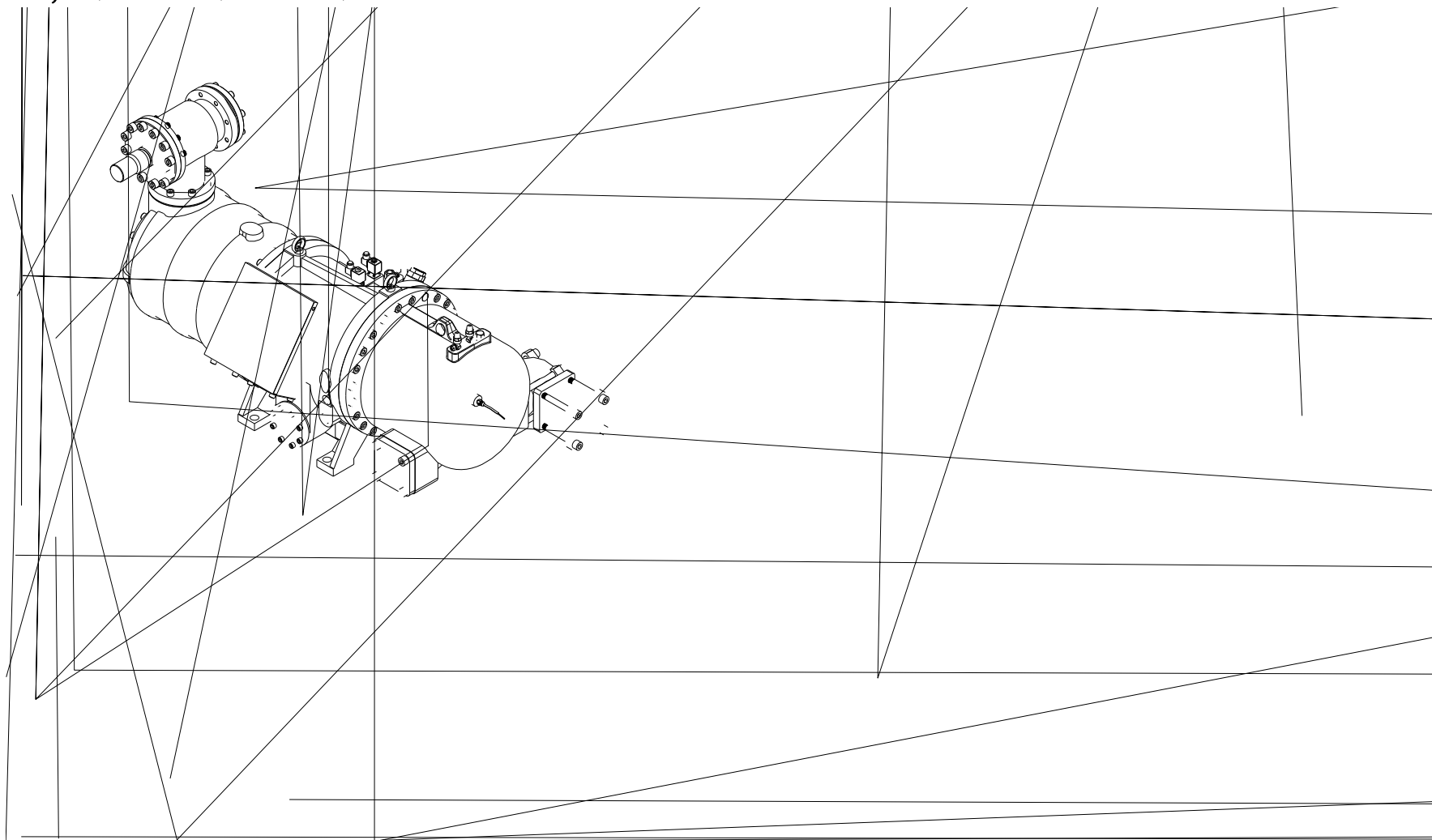

B1, 0/1/A %002/A

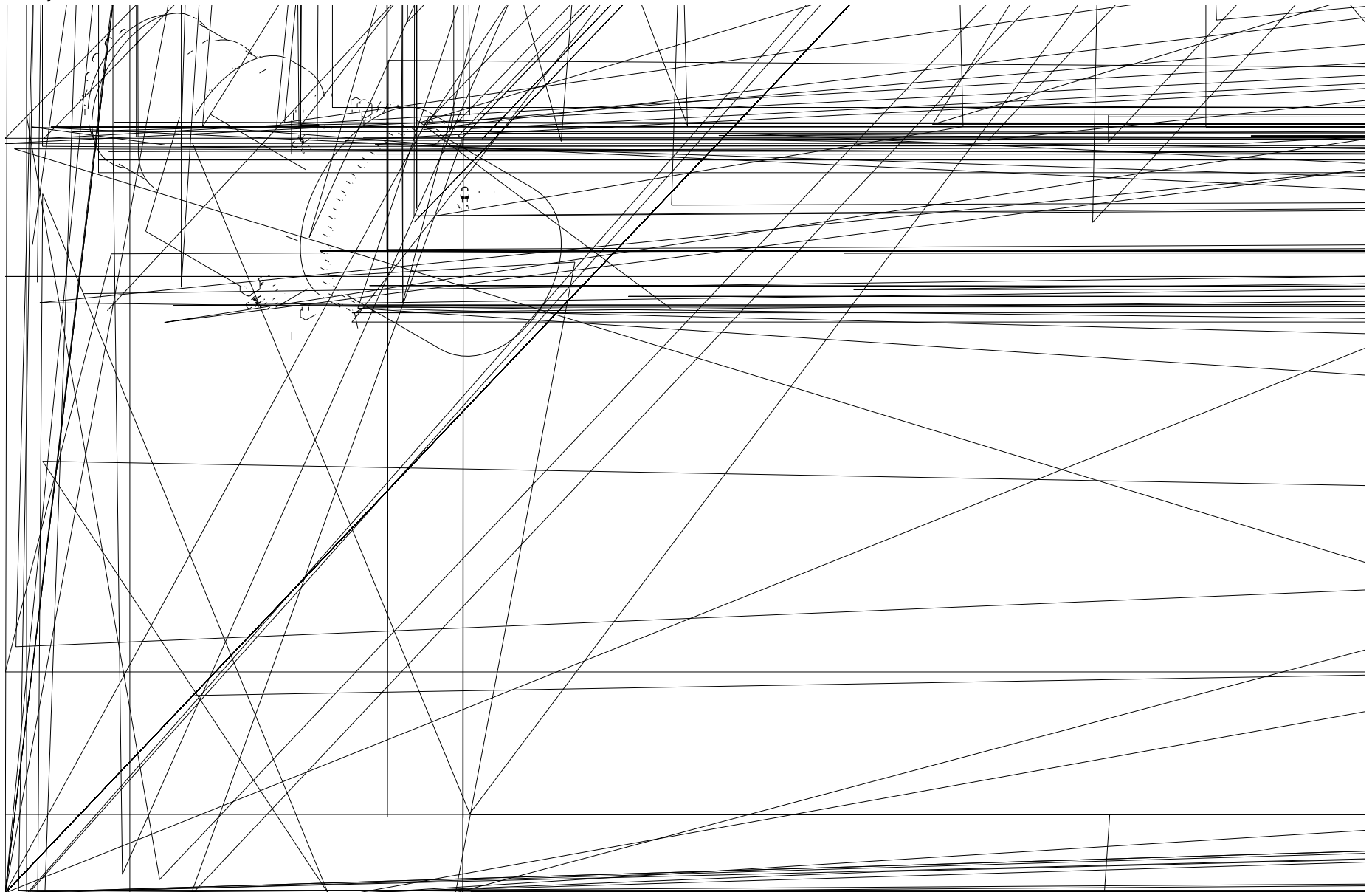

B1, 016/A %042/A

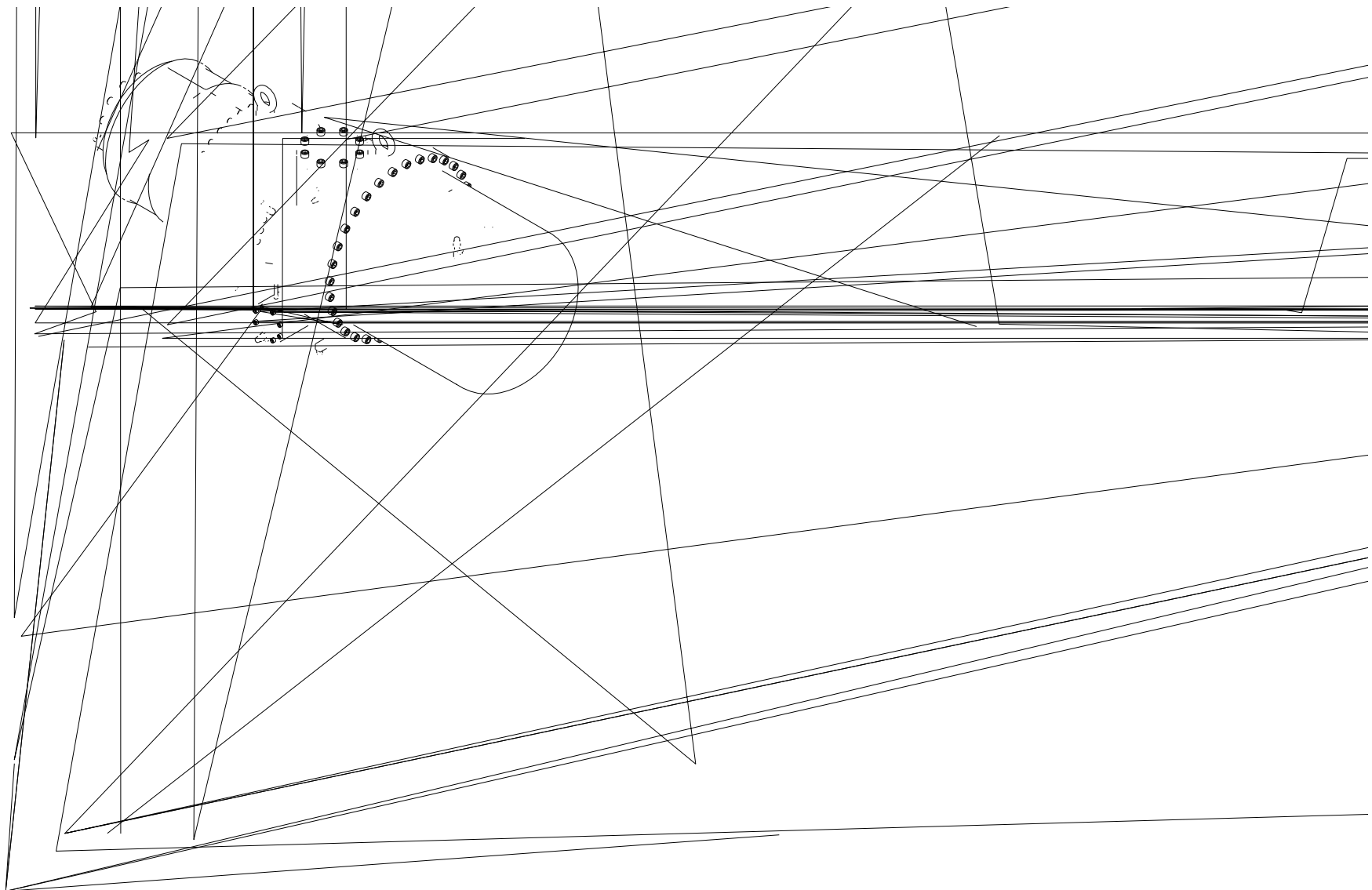

B1 , 0//A 042/A

| | | | | | | | | | | | | | | | | |
|-----------|----------|-----|----------|----------|------|----------|----------|--------|--------|--------|--------|-----|--------|-----|--------|----|
| B1 , 0// | 1! | 44 | 50-2 | 1! | 44 | 50-2 | 4. 7! | 05-0 | 2. 7!E | 8-6 | 2. 7!E | 8-6 | 2. 7!E | 8-6 | | |
| B1 , 03/ | 1! | | | 1! | | | 4. 7! | 05-0 | 2. 7!E | 8-6 | 2. 7!E | 8-6 | 2. 7!E | 8-6 | | |
| B1 , 07/ | 1! | | | 1, 0. 1! | 57 | 66-1 | 4. 7! | 05-0 | 2. 7!E | 8-6 | 2. 7!E | 8-6 | 4. 7!E | 05 | | |
| B1 , 1// | 1! | | | 1, 0. 1! | | | 4. 7! | 05-0 | 4. 7!E | 05 | 2. 7!E | 8-6 | 4. 7!E | 05 | | |
| B1 , 12/ | 1, 0. 1! | 57 | 66-1 | 2! | 7/-4 | 8/-1 | 4. 7! | 05-0 | 4. 7!E | 05 | 2. 7!E | 8-6 | 4. 7!E | 05 | | |
| B1 , 15/ | 1, 0. 1! | | | 2! | | | 4. 7! | 05-0 | 4. 7!E | 05 | 2. 7!E | 8-6 | 4. 7!E | 05 | | |
| B1 , 2// | 1, 0. 1! | | | 2! | | | 6. 7! | 11-3 | 4. 7!E | 05 | 2. 7!E | 8-6 | 4. 7!E | 05 | | |
| B1 , 20/ | 1, 0. 1! | | | 2! | | | 6. 7! | 11-3 | 4. 7!E | 05 | 2. 7!E | 8-6 | 4. 7!E | 05 | | |
| B1 , 23/ | 1, 0. 1! | | | 7/-4 | 8/-1 | 3! | 82 | 00/ | 6. 7! | 11-3 | 4. 7!E | 05 | 2. 7!E | 8-6 | 4. 7!E | 05 |
| B1 , 26/ | 1, 0. 1! | | | | | 3! | | | 6. 7! | 11-3 | 4. 7!E | 05 | 2. 7!E | 8-6 | 4. 7!E | 05 |
| B1 , 30/ | 2! | 3! | 6. 7! | | | 11-3 | | | 4. 7!E | 05 | 2. 7!E | 8-6 | 4. 7!E | 05 | | |
| B1 , 36/ | 2! | 3! | 6. 7! | | | 11-3 | | | 4. 7!E | 05 | 2. 7!E | 8-6 | 4. 7!E | 05 | | |
| B1 , 40/ | 2! | 3! | 0, 0. 7! | | | | | | 4. 7!E | 05 | 2. 7!E | 8-6 | 4. 7!E | 05 | | |
| B1 , 44/ | 2! | 3! | 0, 0. 7! | | | | | | 4. 7!E | 05 | 2. 7!E | 8-6 | 4. 7!E | 05 | | |
| B1 , 47/ | 2! | 82 | 00/ | 3! | 0/5 | 024 | 0, 0. 7! | | 4. 7!E | 05 | 2. 7!E | 8-6 | 4. 7!E | 05 | | |
| B1 , 51/ | 3! | | | 4! | | | 0, 0. 7! | | 4. 7!E | 05 | 2. 7!E | 8-6 | 4. 7!E | 05 | | |
| B1 , 60/ | 3! | | | 4! | | | 0, 0. 7! | | 2. 3!E | 08-1 | 2. 7!E | 8-6 | 4. 7!E | 05 | | |
| B1 , 68/ | 3! | | | 4! | | | 0, 0. 7! | | 2. 3!E | 08-1 | 2. 7!E | 8-6 | 4. 7!E | 05 | | |
| B1 , 72/ | 3! | | | 4! | | | 0, 0. 7! | | 2. 3!E | 08-1 | 2. 7!E | 8-6 | 4. 7!E | 05 | | |
| B1 , 82/ | 3! | | | 4! | | | 0, 0. 7! | | 2. 3!E | 08-1 | 2. 7!E | 8-6 | 4. 7!E | 05 | | |
| B1 , 0/1/ | 4! | 0/5 | 024 | 5! | 048 | 0, 2. 7! | | 2. 3!E | 08-1 | 4. 7!E | 05 | | | | | |
| B1 , 002/ | 4! | | | 5! | | 0, 2. 7! | | 2. 3!E | 08-1 | 4. 7!E | 05 | | | | | |
| B1 , 016/ | 5! | 048 | | 7! | 107 | 1 | 2. 3!E | 08-1 | 4. 7!E | 05 | | | | | | |
| B1 , 042/ | 5! | | | 7! | | 1 | 2. 3!E | 08-1 | 4. 7!E | 05 | | | | | | |



TEL 0531-85060075 2222 U 4
FAX 0531-85060071

TEL 1001 U 6

8289